

**RoofPak™ Applied
Rooftop Systems**

Engineered for flexibility and performance™



RoofPak Applied Rooftop Systems

Design flexibility, energy efficiency, system performance and reliability make McQuay RoofPak applied rooftop systems the ideal solution for your one to eight-story building projects. Available in air-cooled and evaporative-cooled models, with capacities from 15 to 150 tons, they combine the lower installation costs and interior space savings of a roof-mounted system with the operating and maintenance efficiencies of central heating and cooling systems.

With their unique, modular design, RoofPak applied rooftop systems can be customized to fit your building as if they were made for it. The result is superior energy efficiency and indoor air quality. Applications range from offices, schools and libraries, to airport terminals, manufacturing facilities, shopping malls, casinos and condominiums. Arriving at your job site as a complete package, RoofPak applied rooftop systems maximize your design and installed cost savings. They also can add to your building's profit margins year after year with efficient, reliable performance.

All units are ASHRAE 90.1-2007 compliant to meet new federal efficiency requirements. Most units exceed the minimum efficiencies required in 2010 per this guideline (see chart).





RoofPak air-cooled rooftop systems are available with EERs that exceed ASHRAE 90.1-2007 requirements for the year 2010, which are approximately 6% more efficient than ASHRAE 90.1-2004 requirements.

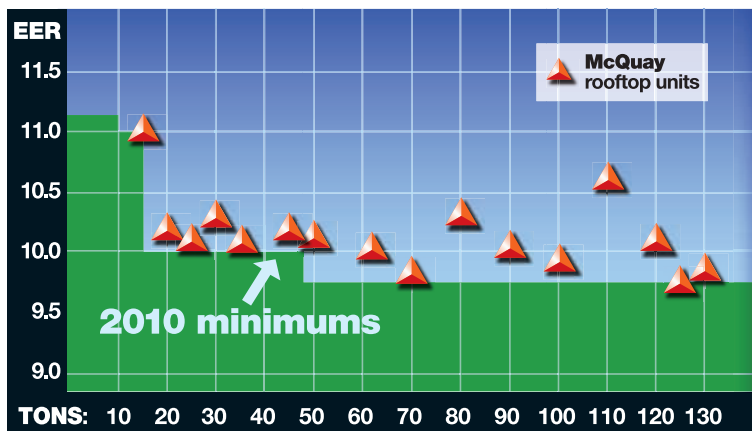



High Efficiency and Low Cost Operation

With some of the highest energy efficiency ratings in the industry, RoofPak applied rooftop systems can deliver the low operating costs that increase profit margins for building owners.

Optimal air design option (50°F supply air) reduces CFM requirements, resulting in lower energy costs and smaller duct work requirements.

Economizer option monitors outdoor and indoor air temperatures and humidity to take full advantage of natural conditions for “free” cooling.

Patented, UltraSeal™ low-leak dampers provide superior leak resistance, reducing energy costs.

Evaporative condensers option consumes up to 40% less compressor energy than competitive air-cooled units and often draws less energy than water-cooled chiller systems because no pumps are required.

High-efficiency airfoil fans and factory-installed variable-frequency drives provide lower fan operating costs and quiet operation.

A wide range of fan sizes, coil face areas, and compressor combinations allows you to optimize selections for operating and energy efficiency.



Airfoil fans are energy efficient and quiet.

Large-face-area intakes/outlets, dampers, filters and coils reduce system pressure drops, improving operating and energy efficiency.

Full double-wall construction with R-6.5 insulation reduces cabinet heat loss/gain, improving operating and energy efficiency.

Energy recovery wheels option recovers approximately 75% of both sensible and latent energy from the exhaust air to reduce energy consumption.

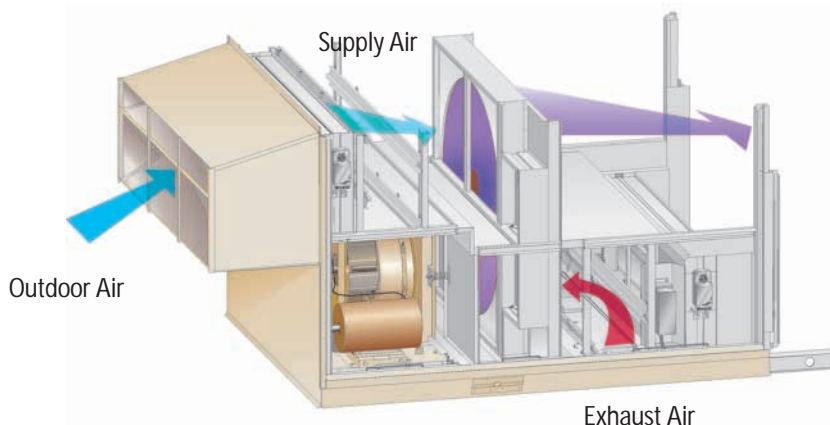

Factory-installed energy recovery wheels offer a cost-effective and efficient method to reduce energy costs while meeting the ventilation requirements of ASHRAE Standard 62.1-2001.



Superior Indoor Air Quality

RoofPak applied rooftop systems provide superior indoor air quality control that keeps owners and tenants satisfied.

Stainless steel, sloped drain pan eliminates standing water.

Full double-wall construction avoids damage to unit insulation and encourages regular cleaning to inhibit microbial growth.

Flexible filter options, including charcoal filters, electronic filters and 95% blow-through final filters, allow you to meet virtually any application requirement.

Optional, factory-installed UVGI lamps (ultraviolet germicidal irradiation) can improve IAQ by destroying mold, fungi and bacteria on coil and drain pan surfaces.

DesignFlow™ precision ventilation air control system continuously controls outdoor air intake volume with an accuracy of $\pm 5.0\%$ to precisely maintain minimum fresh air intake per ASHRAE Standard 62.1-2004.



Filter choices offer a wide range of media selections and face areas to suit your specific applications.

SuperMod™ gas burner with 20:1 turndown provides precise temperature control for tenant comfort in conventional or high minimum outdoor air applications.

Modulating hot gas reheat option provides the ultimate in dehumidification control and is ideal for 100% outdoor air applications.

MicroTech® III humidity control logic maintains comfort conditions in a wide range of applications. Up to 6 steps of compressor capacity control, with hot gas bypass on each circuit, provide stable discharge temperatures and humidity control for superior tenant comfort.

Environmentally friendly R-410A refrigerant is used on air-cooled units and R-407C on evaporative condenser units.

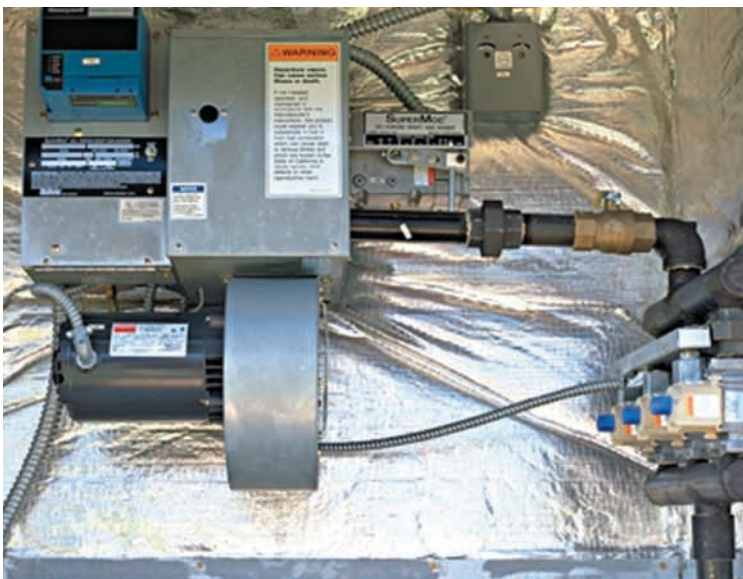

SuperMod™ high turndown gas burner provides precise temperature control for a comfortable tenant environment.



Design Flexibility

Engineers, building owners and contractors can profit from the performance and cost benefits provided by the flexibility of RoofPak applied rooftop systems.

RoofPak Applied Rooftop Systems

What they do for you

Modular flexibility

Lets you specify a unit that precisely meets your requirements.

Blow-through and draw-through coil configurations

Blow-through provides high sensible cooling, a quiet tenant environment and energy savings. Draw-through provides higher latent cooling for make-up air systems or systems with high humidity loads.

100% outdoor air, dehumidification, VAV or constant-volume operation

Lets you match application requirements with the optimum roof-mounted cooling/heating solution.

Multiple filter, fan, coil and heating options in flexible sizes

Lets you match system requirements, resulting in energy savings, superior indoor air quality and lower maintenance costs.

Return or exhaust air fans

Return air fans provide proper building pressure and outdoor air ventilation control for ducted return systems. Exhaust fans can save energy on plenum return systems with low air pressure drops.

Blank sections throughout the unit

Let you specify factory-installed specialty equipment at lower installation costs while optimizing system performance.

Optional return/supply locations

Let you match system configuration requirements with lower installed costs, reduced air pressure drop and quieter operation.

Copeland® scroll compressors with dual circuits

Provide optimum system performance with proven reliability.

IBC seismic certification

Available with construction that is certified and labeled compliant with International Building Code (IBC) 2009 and ASCE 7-05 seismic requirements for mechanical equipment.

MicroTech® III Controller with Open Choices™ feature

Select either BACnet® or LONWORKS® communications to communicate control and monitoring information to your building automation system without costly gateways. Units with optional LONWORKS communication modules are LONMARK® certified.





Evaporative Condenser Systems

RoofPak units are available with evaporative condensers that use 25 to 50% less compressor kilowatts per ton than competitive air-cooled rooftops. They may also consume less energy than a water-cooled chiller system because no pumps are required.

Walk-In Service Enclosure

- Most refrigerant service can be accomplished within this single enclosure
- User-friendly sound levels because compressors are located outside the enclosure
- Ventilating fan for servicing comfort

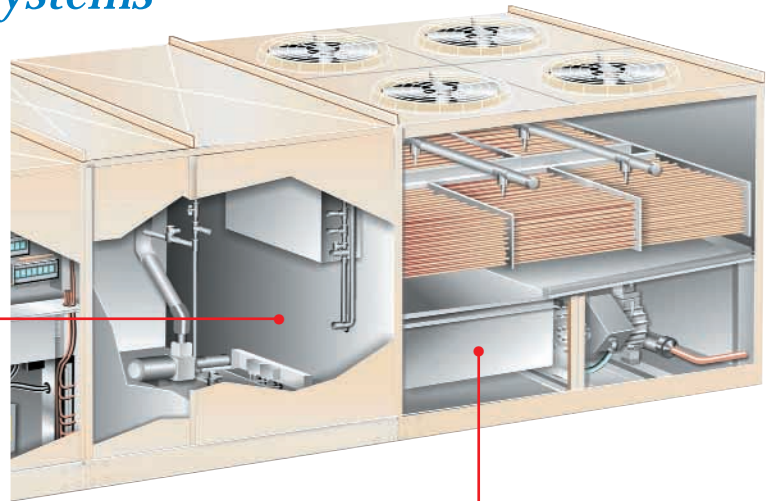

Corrosion-Resistant Design

- All-copper condenser bundles
- Stainless steel sump and spray enclosure
- PVC spray system
- Removable pump and spray nozzles

100% Outdoor Air Applications

Roofpak systems are ideal for 100% outdoor air (DOAS) applications. Units can be equipped with energy recovery wheels and/or modulating hot gas reheat to increase occupant comfort and avoid over-cooling.





Low Cost Installation, Maintenance and Service

RoofPak applied rooftop systems are designed for easy, low-cost installation, maintenance and service. The result is higher profit margins available for building owners.

Units arrive at your job site as a complete package—assembled, factory-tested and ready to go—for quick start-up and reliable performance.

Fully integrated and factory-tested MicroTech® III controls can significantly reduce costly field commissioning and are easily accessed for system diagnostics and quick adjustments.

Large access doors on every section, with single-lever latches and door holders, encourage regular maintenance for peak system performance and extended unit life.

Exact-fit replacement of McQuay models dating back 30 years—using existing roof curbs—for easy, low-cost installation of upgraded units.

Recessed condenser coils provide built in hail protection.



Hinged access doors on both sides of each section put all components within easy reach for maintenance and service.



Exact-fit replacement units make it easy to replace older units with modern McQuay technology.



Durable Design and Construction

McQuay is a proven manufacturer of high-quality applied rooftop systems known for durability and reliable performance.

Leak-resistant cabinet design with prepainted surfaces withstands the toughest operating conditions — from high humidity and salt air, to severe cold and heat.

Full double-wall construction can extend the life of the unit by avoiding insulation damage and allowing interior surfaces to be easily cleaned.

Efficient Copeland® semi-hermetic or scroll compressors have proven reliable over years of service in thousands of applications.



Full double-wall construction protects the unit insulation and provides a wipe-clean surface.

McQuay's Unique Features and Options

RoofPak Applied Rooftop Systems

Blow Through System Design (shown)

- High sensible heat ratio for optimized cooling performance and energy efficiency
- Quieter tenant environment by putting distance between fan and building occupants

Draw-Through System Design (not shown)

- High latent cooling for make-up air systems or systems with high humidity loads

Return or Exhaust Fan

- Customize the unit to fit the application and return duct pressure drop
- Exhaust fans typically save energy at low return duct pressure drops
- Return fans provide better building pressure and ventilation control as return duct pressure drop increases

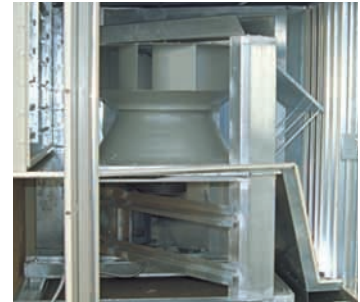

Airfoil Fans

- DWDI airfoil fans with housings provide maximum efficiency
- Flexible selection allows larger diameter, lower RPM choices and quieter operation

Economizer

- Outside air enters from both sides, improving mixing for better temperature control
- DesignFlow™ Precision Ventilation Air Measurement System measures incoming air volume with an accuracy of $\pm 5.0\%$ for optimum control of minimum outdoor air intake and good IAQ
- Patented UltraSeal™ low-leak dampers minimize air leakage, reducing energy costs

Hinged Access Doors

- On both sides of every section for easy access to all components
- Single lever latch and door holders provide easy entry
- Double-wall construction protects insulation during maintenance

Durable Construction

- Pre-painted exterior cabinet panels pass 750-hour ASTM B 117 Salt Spray Test for durability
- Weather-resistant construction with capped seams and sloped top panels
- Double-wall construction protects R-6.5 insulation and provides wipe-clean surface
- Stainless steel, sloped drain pans to avoid standing water

Extended Face Area Filters

- 2" pleated or rigid cartridge

Factory-mounted Variable Frequency Drives

- Control fan motor speed for lower operating costs and quieter operation

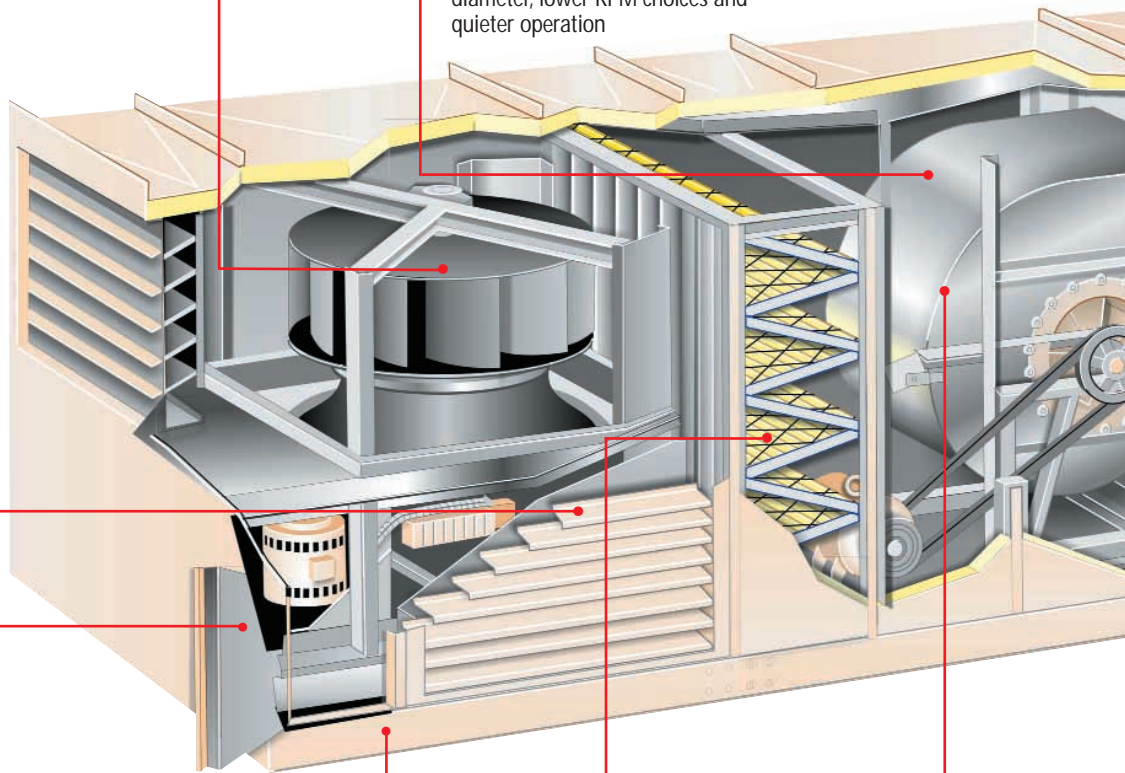



MicroTech III™ Unit Controller

- Easily accessed for system diagnostics and adjustments via a keypad and display on unit
- Remote user interface option provides all functionality of unit-mounted interface
- Outdoor air and humidity control logic maintains minimum fresh air intake and optimum humidity levels



- Open Choices™ feature provides interoperability with BACnet or LonMark certified communications for easy integration into your building automation system of choice

Microchannel Condenser Coils

- Proven technology from the automotive industry
- Suited for R-410A
- All aluminum design
- No corrosion between fins, tubes and header

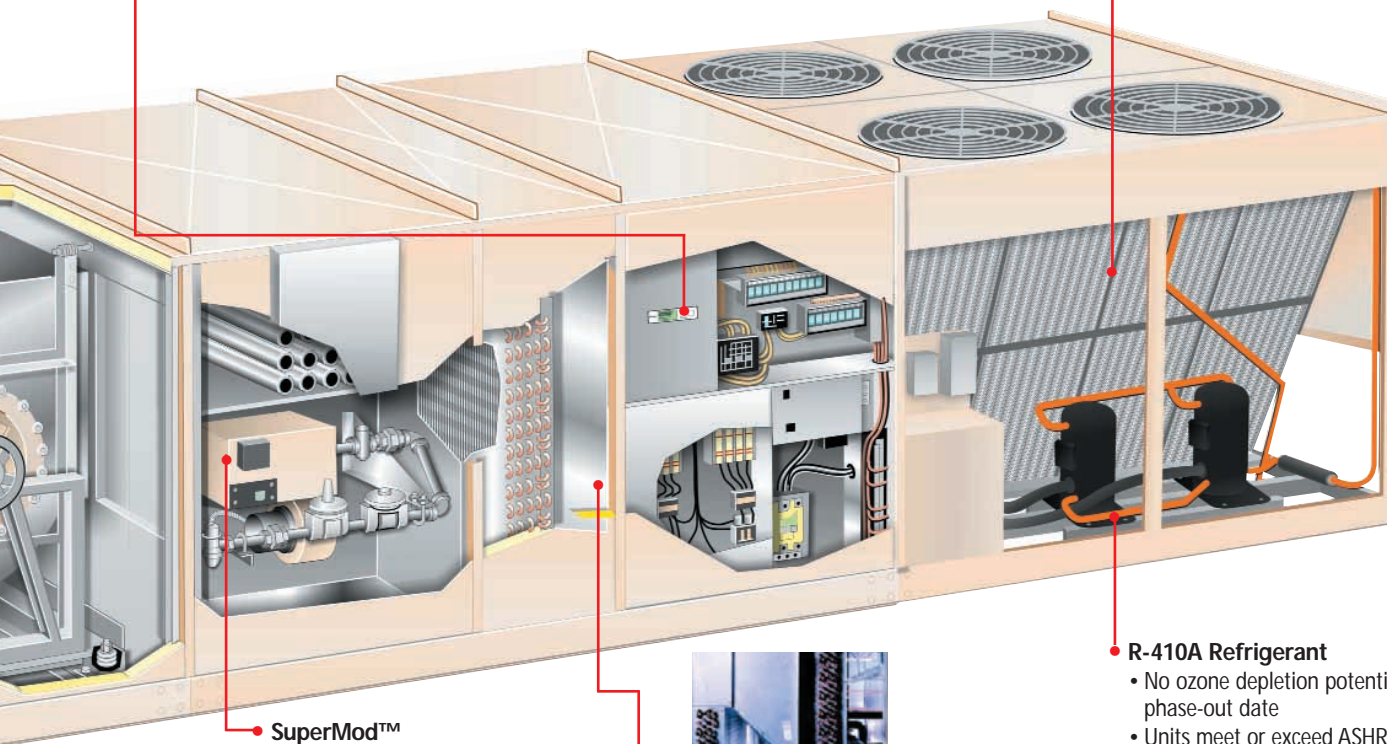

SuperMod™ High Turndown Gas Burner

- Full 20:1 turndown and multiple sizes enable precise temperature control while reducing design, installation, and life-cycle costs
- Maintain comfortable tenant environment in VAV, 100% outdoor air, and dehumidification applications



UVGI Lights

- For pennies a day, UVGI can improve IAQ by destroying mold, fungi, and bacteria on coil and drain pan surfaces

R-410A Refrigerant

- No ozone depletion potential or phase-out date
- Units meet or exceed ASHRAE 90.1-2010 energy requirements
- Dual refrigerant circuits provide redundancy for high unit reliability

Blank Sections

- Available throughout unit to factory-mount air blenders, filters, sound attenuators, humidifiers or other specialty equipment (air purification shown)
- Allow customization for maximum system performance and efficiency
- Reduce design and installation costs



*Note:
The benefits of McQuay's packaged rooftop systems are also available in a rooftop air handler configuration.*

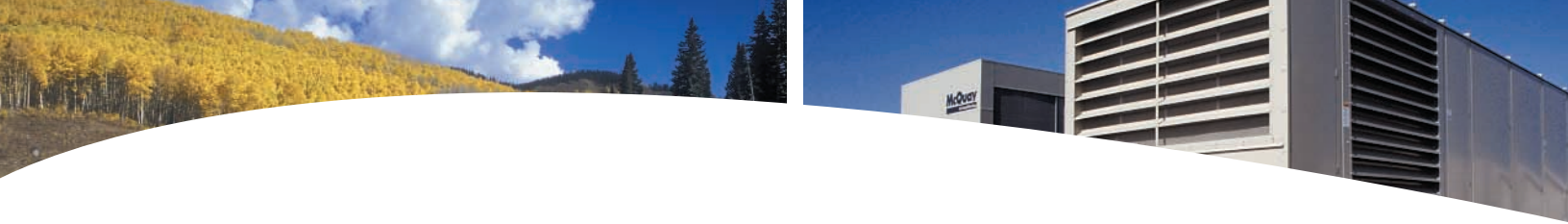

To find out more about McQuay applied rooftop systems,
call your local McQuay representative or visit us at: www.mcquay.com

McQuay International delivers engineered, flexible solutions for commercial, industrial and institutional HVAC requirements with reliable products, knowledgeable applications expertise and responsive support.

For more information or the name of your local McQuay representative, call 1-800-432-1342 or visit www.mcquay.com

Products manufactured in an ISO certified facility.

McQuay[®]
International
*a member of **DAIKIN** group*

(800) 432-1342
www.mcquay.com

© 2009 McQuay International
A/SP 31-156 (11/09)