

Group: Controls

Part Number: IM 968

Date: October 2009

Supercedes: New

MicroTech[®] III McQuay Chiller Unit Controller LONWORKS[®] Communication Module

Pathfinder[™] Chiller, Model AWS



NOTICE

Use this manual to physically connect the LonWorks Communication Module to the the MicroTech III Chiller Unit Controller and connect the chiller unit controller to your network. Only personnel knowledgeable in the operation of the equipment being controlled must perform connections and service to the MicroTech III Chiller Unit Controller. Use the appropriate McQuay Engineering Data (ED), known as the Protocol Information document, to integrate the unit into your network. The Protocol Information document contains addressing details, LONWORKS[®] protocol information, and a list of the data points available to the network. See the Reference Documents section of this manual for Protocol Information document numbers. MicroTech III control integration literature is available from your local McQuay International sales representative and www.mcquay.com.

Table of Contents

Figures	2
Revision History	3
Reference Documents	3
Limited Warranty	3
Notice.....	3
General Information.....	4
Hazard Identification Messages	4
Description.....	5
Application.....	5
Component Data	5
Service Pin	6
Light Emitting Diodes (LEDs).....	7
LONWORKS Network Connector	7
Board-To-Board Connector	7
LonMark Profile Software	7
Neuron ID	7
Transceiver.....	8
Specifications.....	8
Installation	9
Contents of the LONWORKS Communication Module Kit.....	9
Installing a new LONWORKS Communication Module.....	9
To install a LONWORKS Communication Module	9
Replacing an Existing LONWORKS Communication Module	10
To replace a LONWORKS Communication Module.....	10
Integration.....	12
Connecting to the Network	12
Addressing and Establishing Communications.....	12
LONWORKS Network Addressing	12
Commissioning the Network	12
External Interface File (XIF) and NXE Files.....	12
Resource Files.....	13
Configuring the LONWORKS Communication Module	13
Service Information.....	15
Test Procedures	15
Parts List	15

Figures

Figure 1. LONWORKS Communication Module Attached to MicroTech III Chiller Unit Controller ...	5
Figure 2. LONWORKS Communication Module Major Components	6
Figure 3. Service Pin Message: Before and After.....	6
Figure 4. LONWORKS Communication Module Knockout	10
Figure 5. Diagram of Board-to-Board Connector	11
Figure 6. LONWORKS Communication Module with Board-to-Board Connector Inserted.....	11

Revision History

IM 968

October 2009

Preliminary release.

Reference Documents

Number	Company	Title	Source
078-0120-01G	LONMARK Interoperability Association	LONMARK Layers 1-6 Interoperability Guidelines, Version 3.4	www.lonmark.org
078-0120-01G	LONMARK Interoperability Association	LONMARK Application Layer Interoperability Guidelines, Version 3.4	www.lonmark.org
078-0156-01G	Echelon® Corporation	LONWORKS® FTT-10A Free Topology Transceiver Users Guide	www.echelon.com
8040_10	LONMARK Interoperability Association	Chiller Profile	www.lonmark.org
IM 1002 (50Hz) IM 997 (60Hz)	McQuay International	Pathfinder™ Air Cooled Chiller Installation Manual	www.mcquay.com
OM 998	McQuay International	Pathfinder™ Air Cooled Chiller Installation Manual	www.mcquay.com
ED 15120	McQuay International	MicroTech III Chiller Unit Controller Protocol Information, BACnet and LONWORKS Networks	www.mcquay.com

Limited Warranty

Consult your local McQuay Representative for warranty details. Refer to Form 933-43285Y. To find your local McQuay Representative, go to www.mcquay.com.

Notice

Copyright © 2009 McQuay International, Minneapolis MN. All rights reserved throughout the world.

McQuay International reserves the right to change any information contained herein without prior notice. The user is responsible for determining whether this software is appropriate for his or her application.

®™ The following are trademarks or registered trademarks of their respective companies.

LONWORKS, LONMARK, LonTalk, and Neuron from Echelon Corporation; Windows from Microsoft Corporation; McQuay and MicroTech III from McQuay International. LONMARK and the LONMARK logo are managed, granted, and used by LONMARK International under a license granted by Echelon Corporation.

General Information

This manual contains the information you need to install a LONWORKS® Communication Module on a MicroTech III Chiller Unit Controller and integrate it into the network.

Hazard Identification Messages

DANGER

Dangers indicate a hazardous situation that will result in death or serious injury if not avoided.

WARNING

Warnings indicate potentially hazardous situations, which can result in property damage, severe personal injury, or death if not avoided.

CAUTION

Cautions indicate potentially hazardous situations, which can result in personal injury or equipment damage if not avoided.

WARNING

Electric shock hazard. Can cause personal injury or equipment damage.

This equipment must be properly grounded. Only personnel knowledgeable in the operation of the equipment being controlled must perform connections and service to the MicroTech III Chiller Unit Controller.

CAUTION

Static sensitive components. Can cause equipment damage.

Discharge any static electrical charge by touching the bare metal inside the control panel before performing any service work. Never unplug cables, circuit board terminal blocks, or power plugs while power is applied to the panel.

NOTICE

This equipment generates, uses and can radiate radio frequency energy and, if not installed and used in accordance with this instruction manual, may cause interference to radio communications. It has been tested and found to comply with the limits for a Class A digital device, pursuant to part 15 of the FCC rules. These limits are designed to provide reasonable protection against harmful interference when the equipment is operated in a commercial environment. Operation of this equipment in a residential area is likely to cause harmful interference in which case the user will be required to correct the interference at his or her own expense. **McQuay International disclaims any liability resulting from any interference or for the correction thereof.**

Description

A MicroTech III LONWORKS Communication Module provides the interface between a McQuay MicroTech III Chiller Controller and a LONWORKS Local Operating Network (LON). It translates the LonTalk® variables used on the network to the variables used in the unit controller and vice versa. It translates in accordance with the LONMARK Functional Profile. Profiles are interpreted in loaded programs (firmware).

The LONWORKS Communication Module is a printed circuit board with a plastic enclosure that connects to the left side of the McQuay Advanced Web Module (AWM) as shown in Figure 1 or directly to the MicroTech III Chiller Unit Controller.

Note: The AWM is an optional feature that provides remote monitoring and diagnostic capability for certain models of McQuay chillers. Please refer to supporting literature, available on www.mcquay.com, for additional details about the AWM.

Application

A LONWORKS Communication Module connects the unit controller to the building automation system (BAS) on a LONWORKS network. It is the interface adapter for the exchange of LonTalk variables between the network and the unit controller. The LONWORKS Communication Module translates the LonTalk variables of the profile into the native information of the unit controller. Refer to the MicroTech III Chiller Unit Controller Operation Manual for keypad details.

Component Data

Figure 1 shows the LONWORKS Communication Module, located on the far left-hand side of the image below. It is connected to the AWM, which is mounted directly to the unit controller.

Figure 1. LONWORKS Communication Module Attached to MicroTech III Chiller Unit Controller

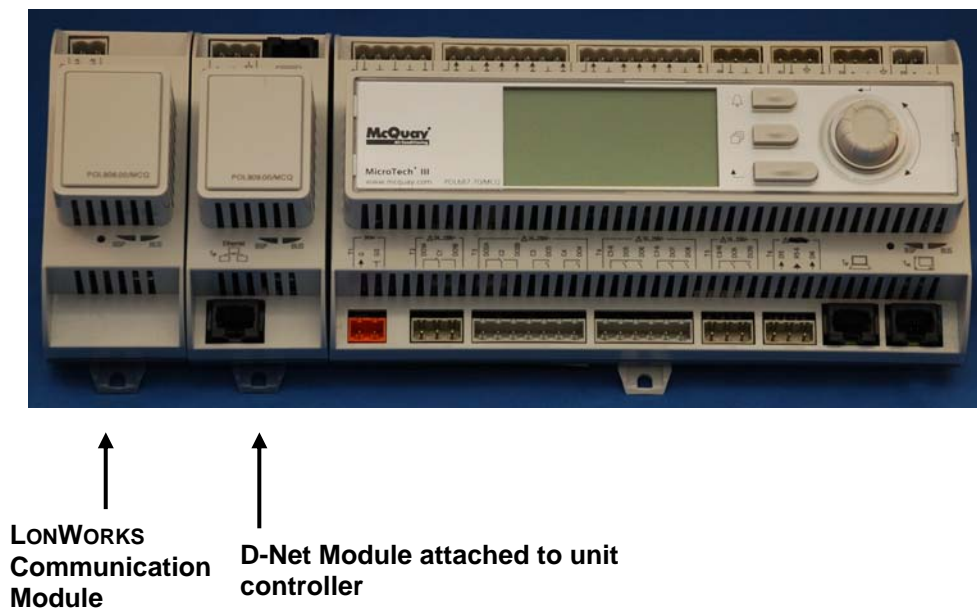
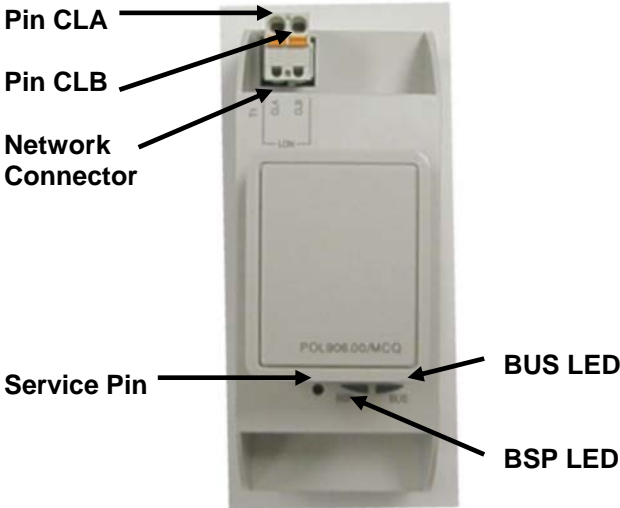

Figure 2 shows the location of the major components of the LONWORKS Communication Module.

Figure 2. LONWORKS Communication Module Major Components



Service Pin

The service pin generates a service-pin message that contains the Neuron[®] ID and the program code identification of the node. A service-pin message is a network message that is generated by a node and broadcast on the network. It can be used to commission the LONWORKS network.

The service pin button is located below the enclosure just left of the LEDs. To activate the service pin, insert the end of a 5/64 “ (1.985 mm) Hex Key (Allen wrench), or other similar tool with a narrow end, approximately 1.5 inches (3.8 cm) into the small hole to the left of the LEDs (see Figure 3).

Figure 3. Service Pin Message: Before and After



Light Emitting Diodes (LEDs)

Two LEDs indicate communication activity and status of the LONWORKS Communication Module. These indicators can be seen when the LONWORKS Communication Module is connected to the MicroTech III Chiller Unit Controller.

BSP LED

The BSP LED indicates the communication status between the LONWORKS Communication Module and the MicroTech III Chiller Unit Controller. The table below describes the status of the BSP LED.

BSP LED Color	Meaning
Flashing between Red & Green	Board Support Package (BSP) upgrade in progress
Green	Communication is established between the communication module and the unit controller.
Yellow	The communication module is capable of communicating to the unit controller. However, communication is not established.
Red flashing with 2Hz	Red flashing with 2Hz = Software error. ¹
Red	Hardware error. ¹

¹ In the event that this should occur, cycle power to the unit controller to attempt to clear the problem. Contact the McQuay Controls Customer Support Group at 866-4MCQUAY (866-462-7829) for additional assistance if necessary.

BUS LEDs

The BUS LED indicates the communication status between the LONWORKS Communication Module and the network. The table below describes the status of the BUS LED.

BUS LED Color	Meaning
Green	The unit controller is capable of communicating to the network.
Red	The unit controller is not capable of communicating to the network.
Orange / Yellow	Communication module is initializing.
Orange / Yellow Flashing	Unit has not yet communicated with a LON network

LONWORKS Network Connector

The network connector connects the LONWORKS Communication Module to the LONWORKS FTT-10A bus.

Pin	Function
CLA	FTT-10A
CLB	FTT-10B

Board-To-Board Connector

The board-to-board connector connects the unit controller to the LONWORKS Communication Module (see Figures 4, 5, and 6).

LonMark Profile Software

The LONWORKS Communication Module software translates the Standard Network Variable Types (SNVTs) and Standard Network Configuration Parameter Types (SCPTs) in accordance with the LONMARK profiles used on the LONWORKS network into the variables and parameters used in the MicroTech III Chiller Unit Controller.

Neuron ID

The basis of the LONWORKS Communication Module is an Echelon Neuron integrated circuit. Each Neuron chip contains a globally (i.e., worldwide) unique, 48-bit serial number called the Neuron ID. The Neuron ID can be used to address the device on the LONWORKS network.

Transceiver

The Echelon Corporation Free Topology Transceiver (FTT-10A) is used to communicate on the LONWORKS network. The network topology may consist of a star, daisy-chain, or other topology. Data transmission rate on the network is 78 kbps (baud).

Specifications

Characteristic	Description
Network Topology	Flexible Free Topology
Neuron Chip Processor	3150
Free Topology Transceiver (FTT-10A)	50051
Cable Types	TIA Category 5 (recommended)
Maximum Bus Length	1476 ft (450) meters per segment
Maximum Node Separation	820 ft (250 meters)
Data Transmission	Two-wire, half duplex
Data Transmission Rate	78 kbps (baud)

Installation

The following section describes how to field install a new LONWORKS Communication Module or replace an existing LONWORKS Communication Module on the MicroTech III Chiller Unit Controller so that it can be incorporated into the LONWORKS network.

CAUTION

Electrostatic discharge hazard.

Can cause equipment damage.

This equipment contains sensitive electronic components that may be damaged by electrostatic discharge from your hands. Before you handle a communications module, you need to touch a grounded object, such as the metal enclosure, in order to discharge the electrostatic potential in your body.

Contents of the LONWORKS Communication Module Kit

The following is the list of items included in the field-installed kit:

- The LONWORKS Communication Module
- Board-to-board connector
- Installation Manual (IM 968)

Installing a new LONWORKS Communication Module

Follow these steps to install a LONWORKS Communication Module on the unit controller. The LONWORKS Communication Module can be connected directly to the unit controller itself or to an existing module, if one is attached.

To install a LONWORKS Communication Module

WARNING

Electric shock hazard. Can cause personal injury or equipment damage.

This equipment must be properly grounded. Only personnel knowledgeable in the operation of the equipment being controlled must perform connections and service to the MicroTech III Chiller Unit Controller.

1. Remove power from the unit controller.
2. Remove the knockout on the far left end of the unit controller itself (or additional module, if present). See Figure 4.

Note: To prevent damage to the unit controller, insert a small screwdriver or other tool to the tab on the bottom of the unit controller and pull the screwdriver away from the controller.

3. Remove the knockout on the right side of the LONWORKS Communication Module.
4. Insert the board-to-board connector into the LONWORKS Communication Module (see Figures 4 and 5). Note that it only fits one way and that the baffles must line up with corresponding slots in LONWORKS Communication Module and the unit controller (see Figures 5 and 6).
5. Insert the other end of the board-to-board connector to the far-left side of the unit controller or other device (i.e. module), if attached (see Figure 1).

6. Connect the LONWORKS Communication Module to the network by inserting a network cable into the communication module's network connector (see Figure 2).
7. Power up the unit controller.
8. The unit controller automatically resets itself approximately 30 seconds after it is powered up. This reset is necessary so that the LONWORKS Communication Module is synchronized with the unit controller.

Note: There is a limit of three devices that can be attached to the left side of the unit controller.

Replacing an Existing LONWORKS Communication Module

Follow these steps to remove an existing LONWORKS Communication Module from unit controller and replace it with a new LONWORKS Communication Module.

To replace a LONWORKS Communication Module

⚠ WARNING

Electric shock hazard. Can cause personal injury or equipment damage.

This equipment must be properly grounded. Only personnel knowledgeable in the operation of the equipment being controlled must perform connections and service to the MicroTech III Chiller Unit Controller.

1. Remove power from the unit controller.
2. Locate the LONWORKS Communication Module to the left of the unit controller (see Figure 1).
3. Pull the network cable connector from the LONWORKS Communication Module.
4. Grasp the LONWORKS Communication Module and carefully pull it from the unit controller (or from an adjacent module, if it is attached to one.)
5. Install the new LONWORKS Communication Module (see steps 2-5 from previous section).
6. Insert the network cable connector into the LONWORKS Communication Module (see Figure 2 for location of network connector).
7. Power up the unit controller.
8. The unit controller automatically resets itself approximately 30 seconds after it is powered up. This reset is necessary so that the LONWORKS Communication Module is synchronized with the unit controller.

Figure 4. LONWORKS Communication Module Knockout

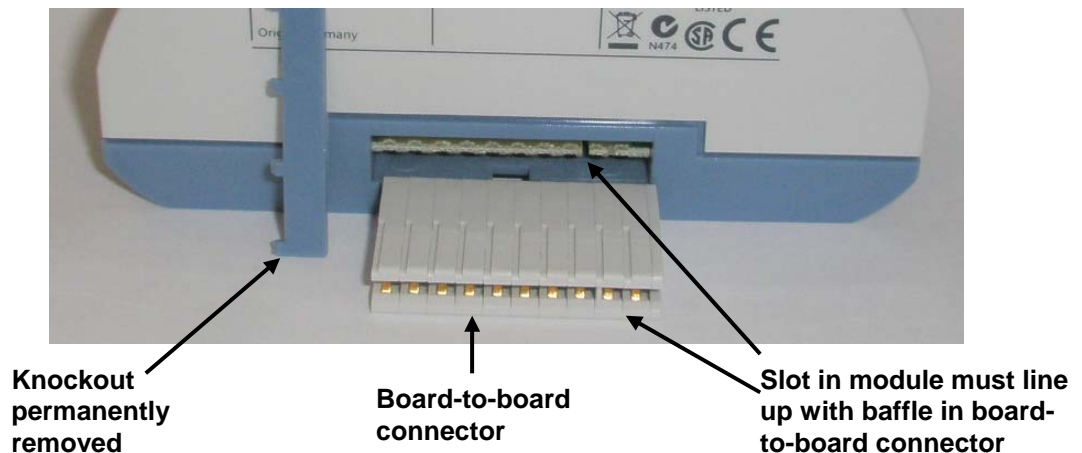

Figure 5. Diagram of Board-to-Board Connector

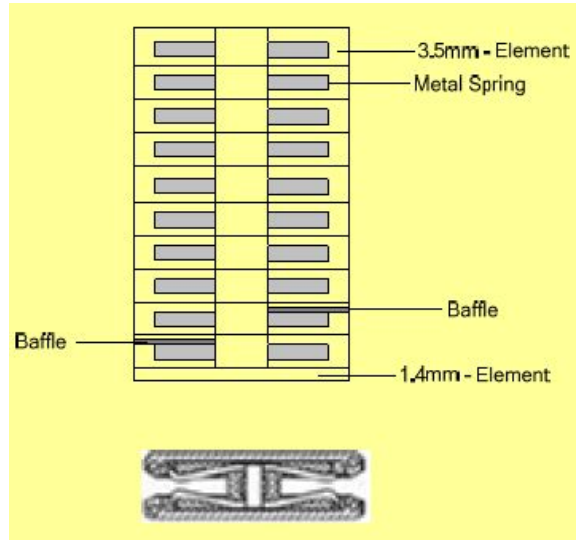

Figure 6. LONWORKS Communication Module with Board-to-Board Connector Inserted



Integration

Once the LONWORKS Communication Module has been properly installed on the MicroTech III Chiller Unit Controller, it is then necessary to configure the unit controller for integration into a Building Automation System (BAS) via the LONWORKS network. The configuration process is described in the following section.

Connecting to the Network

After you have installed the LONWORKS Communication Module to the MicroTech III Chiller Unit Controller, you must connect it into the LONWORKS network. Each LONWORKS Communication Module is equipped with an FTT-10A transceiver for network communications. This transceiver allows for (1) free topology network wiring schemes using twisted pair (unshielded) cable and (2) polarity insensitive connections at each node. Free topology segments require termination for proper transmission performance.

Refer to Echelon LONWORKS FTT-10A Transceiver User's Guide for details regarding acceptable configurations, cabling requirements, terminations, and other requirements for proper connection of the unit to the LONWORKS network.

Addressing and Establishing Communications

LONWORKS Network Addressing

Every Neuron Chip has a unique 48-bit Neuron ID or physical address. This address is generally used only at initial installation or for diagnostic purposes. For normal network operation, a device address is used.

Device addresses are defined at the time of network configuration. All device addresses have three parts. The first part is the Domain ID, designating the domain. Devices must be in the same domain in order to communicate with each other. The second part is the Subnet ID that specifies a collection of up to 127 devices that are on a single channel or a set of channels connected by repeaters. There may be up to 255 subnets in a domain. The third part is the Node ID that identifies an individual device within the subnet.

A group is a logical collection of devices within a domain. Groups are assembled with regard for their physical location in the domain. There may be up to 256 groups in a domain. A group address is the address that identifies all devices of the group. There may be any number of devices in a group when unacknowledged messaging is used. Groups are limited to 64 devices if acknowledged messaging is used.

A broadcast address identifies all devices within a subnet or domain.

Commissioning the Network

- To commission the device (i.e. LONWORKS Communication Module), press the service pin (see Figure 3). Doing so generates a service-pin message, which is broadcast on the network and contains the Neuron ID and the program code identification of the node.
- Next, use a LONWORKS network configuration tool, such as LonMaker[®], to map the device Neuron ID to the domain/subnet/node logical addressing scheme when it creates the network image, the logical network addresses and connection information.
- Cycle power to the unit controller after 1) commissioning a device, 2) de-commissioning an existing device, and 3) subsequent re-commissioning of an existing device.

External Interface File (XIF) and NXE Files

LONMARK guidelines specify exact documentation rules so that proprietary configuration tools are not required to commission and configure LONWORKS devices. The LONWORKS Communication

Module is self-documenting so that any LONWORKS network management tool can obtain all the information needed over the network to connect it into the system and to configure and manage it.

An external interface file (a specially formatted PC text file with the extension .XIF) is required, along with LONWORKS network management tool, so that you can design and configure the device prior to installation.

The NXE file contains the application image that is downloaded into the MicroTech III LONWORKS Communication Module.

The XIF and NXE files are available at www.mcquay.com or lonmark.org. Refer to McQuay ED 15120, MicroTech III Chiller Unit Controller Protocol Information, for additional details.

Resource Files

Resource files contain definitions of functional profiles, network variables types, configuration property types, and enumerations. Resource files are required for displaying McQuay-specific variables that are not included in the standard device profile. The LONWORKS Communication Module uses the McQuayChiller (scope 5) resource files. These files are available at www.mcquay.com or www.lonmark.org. Refer to McQuay ED 15120 for additional details.

Configuring the LONWORKS Communication Module

The LONWORKS Communication Module typically does not require configuration. However, the available network parameters are available under the LON Setup menu. Table 1 describes these configurable parameters. Table 1 also defines the factory defaults (as indicated by the Initial Value/Note column) for each network parameter.

Refer to the MicroTech III Chiller Unit Controller Operation Manual for additional information on using keypad/display to set unit parameters and factory defaults for unit setpoints. Refer to ED 15120 for descriptions of the available LONWORKS variables.



If a password has been entered, a numerical value appears (in this case, 2)

Back button

Circular knob (press down to Enter value)

Configurable Parameters

Table 1 defines the network parameters of the LONWORKS Communication Module that are available on the Main Menu_View/Set Unit_LON Setup menu of the keypad/display. Some provide information about the LonWorks Communication Module and some are parameters that can be set using the keypad/display. Change parameters as required for your network.

Table 1. LONWORKS Setup Menu

Parameter	Value (Range)/Definition	Initial Value/Note
Neuron ID	variable/This is the neuron ID of the LONWORKS module.	variable/This item will be blank if the communication module is not commissioned.
Max Send Time	0-6553.5/Max Send Time. This configuration network parameter controls the maximum period of time that expires before certain network variables are transmitted. See ED 15120 for more information.	0 Seconds/This variable can also be changed using a LonWorks tool by changing nciMaxSendTime.
Min Send Time	0-6553.5/Min Send Time. This configuration network parameter controls the minimum period of time that expires before objects can be retransmitted. See ED 15120 for more information.	10 Seconds/This variable can also be changed using a LonWorks tool by changing nciMinSendTime.
Rcv Heartbeat	0-6553.5/Receive Heartbeat. This property defines the maximum time that elapses after the last update to a specified network variable input before the unit starts to use its default values.	0 Seconds/This variable can also be changed using a LonWorks tool by changing nciRCvHrtBt.
Lon BSP	Basic Support Package Version	8.002
Lon App Ver	Variable/This property defines the version of the application that is loaded into the LonWorks Communication Module.	variable/A value of Chlr2* (where * is the revision) indicates that this LonWorks module is loaded with application for a centrifugal chiller. Chlr1* is used for all other chiller types. This item will remain blank until the LonWorks Communication Module is commissioned.

Note: If unit controller application software requires downloading in the field, the network configuration parameters revert to their default values. Please contact the Technical Response Center at 877-349-7782 for assistance with upgrading unit controller application software.

Service Information

Test Procedures

If you can control the unit from the keypad, but you are unable to communicate with it via the network:

- Check the network wiring.
- Check addressing.
 - Activate the Service Pin on the LONWORKS Communication Module to send the service message to the network.
 - The service-pin message contains the Neuron ID and the program code identification of the node.

Contact the McQuay Controls Customer Support group at 866-4MCQUAY (866-462-7829) for additional assistance if necessary.

Parts List

Description	Part Number
MicroTech III Chiller Communication Module, LONWORKS Kit (kit includes communication module, board-to-board connector, and Installation Manual)	350147412

This document contains the most current product information as of this printing. For the most current product information, please go to www.mcquay.com. All McQuay equipment is sold pursuant to McQuay's Standard Terms and Conditions of Sales and Limited Warranty

