

Group: **Chiller**

Part Number: **331374701**

Effective: June **2009**

Supersedes: **OM WMC-3**

## **Magnitude™ Frictionless Centrifugal Chillers**

**Model WMC 145S – 400D**

**OITS Software Version: 2.01.01**

**Control Software Version: WMCU3UU02B**

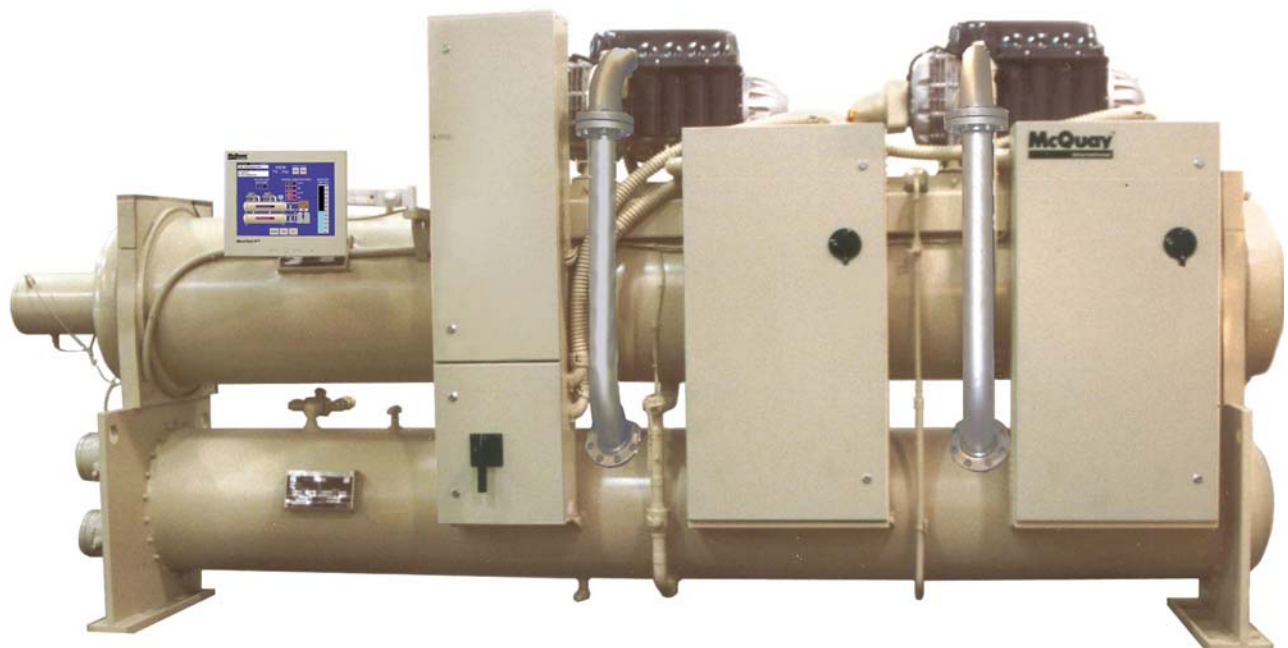

# Table of Contents

<b>Introduction .....</b>	<b>3</b>	Compressor Controller Functions.....	26
<b>Features of the Control Panel.....</b>	<b>4</b>	<b>Compressor On-Board</b>	
<b>Definitions .....</b>	<b>5</b>	<b>Controllers .....</b>	<b>30</b>
<b>General Description .....</b>	<b>8</b>	<b>Interface Touch Screen.....</b>	<b>32</b>
<b>Control Panel .....</b>	<b>10</b>	Navigation .....	32
<b>Use with On-Site Generators.....</b>	<b>11</b>	Screen Descriptions .....	34
<b>Sequence of Operation .....</b>	<b>12</b>	VIEW Screens .....	34
<b>Multi-Chiller Setup .....</b>	<b>13</b>	SET Screens.....	39
Operating Limits:.....	14	SERVICE Screen.....	52
<b>Operating the Control System.....</b>	<b>15</b>	HISTORY Screens.....	53
Interface Panel On/Off.....	15	Download Data.....	54
Start/Stop Unit .....	15	ACTIVE ALARM Screen .....	55
Change Setpoints .....	15	<b>Unit Controller Menu Screens.....</b>	<b>57</b>
Alarms .....	15	Menu Matrix .....	58
Component Failure .....	16	<b>Compressor Controller Menu</b>	
<b>Component Description .....</b>	<b>16</b>	<b>Screens .....</b>	<b>74</b>
Operator Interface Touch Screen .....	16	Menu Matrix .....	74
Unit/Compressor Controller Description.....	16	<b>BAS Interface .....</b>	<b>76</b>
Navigating .....	17	<b>Maintenance .....</b>	<b>77</b>
<b>Unit Controller.....</b>	<b>19</b>	Pressure/Temperature Chart.....	77
Unit Controller Setpoints.....	19	Routine Maintenance .....	77
Faults, Problems, Warnings .....	21	Repair of System .....	78
Unit Controller Functions.....	22	<b>Maintenance Schedule.....</b>	<b>81</b>
<b>Compressor Controller .....</b>	<b>23</b>	<b>Service Programs .....</b>	<b>82</b>
Compressor Controller Setpoints.....	24	<b>Operator Schools.....</b>	<b>82</b>
Compressor Faults, Problems, Warnings.....	25	<b>Limited Warranty .....</b>	<b>82</b>



**Manufactured in an ISO Certified Facility**

©2009 McQuay International. Illustrations and data cover the McQuay International product at the time of publication and we reserve the right to make changes in design and construction at anytime without notice.™® The following are trademarks or registered trademarks of their respective companies: BACnet from ASHRAE; LONMARK, LonTalk, LONWORKS, and the LONMARK logo are managed, granted and used by LONMARK International under a license granted by Echelon Corporation; Modbus from Schneider Electric; MicroTech II, and Open Choices from McQuay International.

# Introduction

This manual provides setup, operating, and troubleshooting information for McQuay Magnitude™ centrifugal chillers with the MicroTech II® controller. Please refer to the current version of IM 1029 for information relating to the unit.

## WARNING

Electric shock hazard. Improper handling of this equipment can cause personal injury or equipment damage. This equipment must be properly grounded. Connections to and service of the MicroTech II control panel must be performed only by personnel that are knowledgeable in the operation of the equipment being controlled..

## CAUTION

Static sensitive components. A static discharge while handling electronic circuit boards can cause damage to the components. Discharge any static electrical charge by touching the bare metal inside the control panel before performing any service work. Never unplug any cables, circuit board terminal blocks, or power plugs while power is applied to the panel.

## NOTICE

**This equipment generates, uses and can radiate radio frequency energy and, if not installed and used in accordance with this instruction manual, may cause interference to radio communications. Operation of this equipment in a residential area is likely to cause harmful interference in which case the user will be required to correct the interference at the owner's own expense.**

**McQuay disclaims any liability resulting from any interference or for the correction thereof.**

## Temperature and humidity considerations

The unit controllers are designed to operate within an ambient temperature range 20°F to 130°F (-7°C to 54°C) with a maximum relative humidity of 95% (non-condensing).

### HAZARD IDENTIFICATION INFORMATION

#### DANGER

Dangers indicate a hazardous situation which will result in death or serious injury if not avoided.

#### WARNING

Warnings indicate potentially hazardous situations, which can result in property damage, severe personal injury, or death if not avoided.

#### CAUTION

Cautions indicate potentially hazardous situations, which can result in personal injury or equipment damage if not avoided.

# Features of the Control Panel

---

- Control of leaving chilled water within a  $\pm 0.2^{\circ}\text{F}$  ( $\pm 0.1^{\circ}\text{C}$ ) tolerance.
- Display of the following temperatures and pressures on a 15-inch Super VGA touch-screen operator interface (depending on date of manufacture):
  - Entering and leaving chilled water temperature
  - Enter and leaving condenser water temperature
  - Saturated evaporator refrigerant temperature and pressure
  - Saturated condenser temperature and pressure
  - Outside air temperature (optional)
  - Suction line, liquid line and discharge line temperatures, calculated superheat for discharge and suction lines, and calculated subcooling for liquid line
- Automatic control of primary and standby evaporator and condenser pumps.
- Control of up to 4 stages of cooling tower fans plus modulating bypass valve and/or tower fan VFD. Although fan staging is available, continuous, modulated control of tower capacity is preferred and recommended.
- History trend feature that will constantly log chiller functions and setpoints. The controller will store and display all accumulated data for recall in a graphic format on the screen. Data can be downloaded for archival purposes.
- Three levels of security protection against unauthorized changing of setpoints and other control parameters.
- Plain language warning and fault diagnostics to inform operators of most warning or fault conditions. Warnings, problems and faults are time and date stamped for identification of when the fault condition occurred. In addition, the operating conditions that existed just prior to shutdown can be recalled to aid in resolving the cause of the problem.
- Twenty-five previous faults and related operating conditions are available from the display. Data can be exported for archival purposes via a 3.5-inch floppy drive or other device (depending on date of manufacture).
- Soft loading feature reduces electrical consumption and peak demand charges during system loop pulldown.
- Remote input signals for chilled water reset, demand limiting and unit enable.
- Manual control mode allows the service technician to command the unit to different operating states. Useful for system checkout.
- BAS communication capability via LONTALK<sup>®</sup>, Modbus<sup>®</sup> or BACnet<sup>®</sup> standard open protocols for most BAS manufacturers.
- Service Test mode for troubleshooting controller outputs.
- Pressure transducers for direct reading of system pressures.
- Preemptive control of low evaporator and high discharge pressure conditions to take corrective action prior to a fault trip.

# Definitions

---

## Active Setpoint

The active setpoint is the parameter setting in effect at any given moment. This variation can occur on setpoints that can be altered during normal operation. Resetting the chilled water leaving temperature setpoint by one of several methods such as return water temperature is an example.

## Active Capacity Limit

The active capacity setpoint is the setting in effect at any given moment. Any one of several external inputs can limit a compressor's capacity below its maximum value.

## Active-Amp-Limit

Active amp limit is the actual amp limit imposed by an outside signal such as the load limit function.

## Condenser Recirc (Recirculation) Timer

A timing function, with a 30-second default, that holds off any reading of condenser water for the duration of the timing setting. This delay allows the sensors to take a more accurate reading of the condenser water temperature.

## Dead Band

The dead band is a set of values associated with a setpoint such that a change in the variable occurring within the dead band causes no action from the controller. For example, if a temperature setpoint is 44°F and it has a dead band of ± 2.0 degrees F, nothing will happen until the measured temperature is less than 42°F or more than 46°F.

## DIN

Digital input usually followed by a number designating the number of the input.

## Discharge Superheat

Discharge superheat is calculated using the following equation:

$$\text{Discharge Superheat} = \text{Discharge Temperature} - \text{Condenser Saturated Temperature}$$

## Error

In the context of this manual, "Error" is the difference between the actual value of a variable and the target setting or setpoint.

## Evaporator Approach

The evaporator approach is calculated for each circuit. The equation is as follows:

$$\text{Evaporator Approach} = \text{LWT} - \text{Evaporator Saturated Temperature}$$

## Evap Hold-loading

This is a setpoint that establishes the minimum evaporator pressure to which the chiller is allowed to go. It signals that the unit is at full load so the no further loading will occur that would lower the pressure even further.

## Evap Recirc (Evaporation Recirculation) Timer

A timing function, with a 30-second default, that holds off any reading of chilled water for the duration of the timing setting. This delay allows the chilled water sensors to take a more accurate reading of the chilled water temperature.

## EXV

Electronic expansion valve, used to control the flow of refrigerant to the evaporator, controlled by the circuit microprocessor.

**Load Limit**

An external signal from the keypad, the BAS, or a 4-20 ma signal that limits the compressor loading to a designated percent of full load. Used to limit unit power input.

**Load Balance**

Load balance is a technique that equally distributes the total unit load between two or more running compressors.

**Low Pressure Hold (Inhibit) Setpoint**

The psi evaporator pressure setting at which the controller will not allow further compressor loading. “Hold” and “Inhibit” are used interchangeably.

**Low Pressure Unload Setpoint**

The psi evaporator pressure setting at which the controller will unload the compressor in an effort to maintain the minimum setting.

**LWT**

Evaporator leaving water temperature. The “water” is any fluid used in the chiller circuit.

**LWT Error**

Error in the controller context is the difference between the value of a variable and the setpoint. For example, if the LWT setpoint is 44°F and the actual temperature of the water at a given moment is 46°F, the LWT error is +2 degrees.

**LWT Slope**

The LWT slope is an indication of the trend of the chilled water temperature. It is calculated by taking readings of the temperature every few seconds and subtracting them from the previous value over a rolling one-minute interval.

**ms**

Milli-second

**Maximum Saturated Condenser Temperature**

The maximum saturated condenser temperature allowed is calculated based on the compressor operational envelope.

**OAT**

Outside ambient air temperature

**Offset**

Offset is the difference between the actual value of a variable (such as temperature or pressure) and the reading shown on the microprocessor as a result of the sensor signal.

**OITS**

Operator Interface Touch Screen, one screen per unit provides operating data visually and accommodates setpoint entry.

**pLAN**

Peco Local Area Network is the proprietary name of the network connecting the control elements.

**Refrigerant Saturated Temperature**

Refrigerant saturated temperature is calculated from the pressure sensor readings. The pressure is fitted to an R-134a temperature/pressure curve to determine the saturated temperature.

**Soft Load**

Soft Load is a control sub-routine that allows the chiller to load up gradually. It requires setpoint inputs of selecting it by Yes or No inputs by selecting the percent load to start ramping up and by selecting the time to ramp up to full load (up to 60 minutes).

**SP**

Setpoint

**Suction Superheat**

Suction superheat is calculated for each circuit using the following equation:

$$\text{Suction Superheat} = \text{Suction Temperature} - \text{Evaporator Saturated Temperature}$$

**Stageup/Stagedown Delta-T**

Staging is the act of starting or stopping a compressor or fan when another is still operating. Startup and Stop is the act of starting the first compressor or fan and stopping the last compressor or fan. The Delta-T is the “dead band” on either side the setpoint in which no action is taken.

**Stage Up Delay**

The time delay from the start of the first compressor to the start of the second.

**Startup Delta-T**

Number of degrees above the LWT setpoint required to start the first compressor.

**Stop Delta-T**

Number of degrees below the LWT setpoint required for the last compressor to stop.

**VDC**

Volts, Direct Current; sometimes noted as vdc.

**VFD**

Variable Frequency Drive, a device located on the compressor used to vary the compressor speed.

# General Description

## Major Components

**Figure 1, Major Component Location**

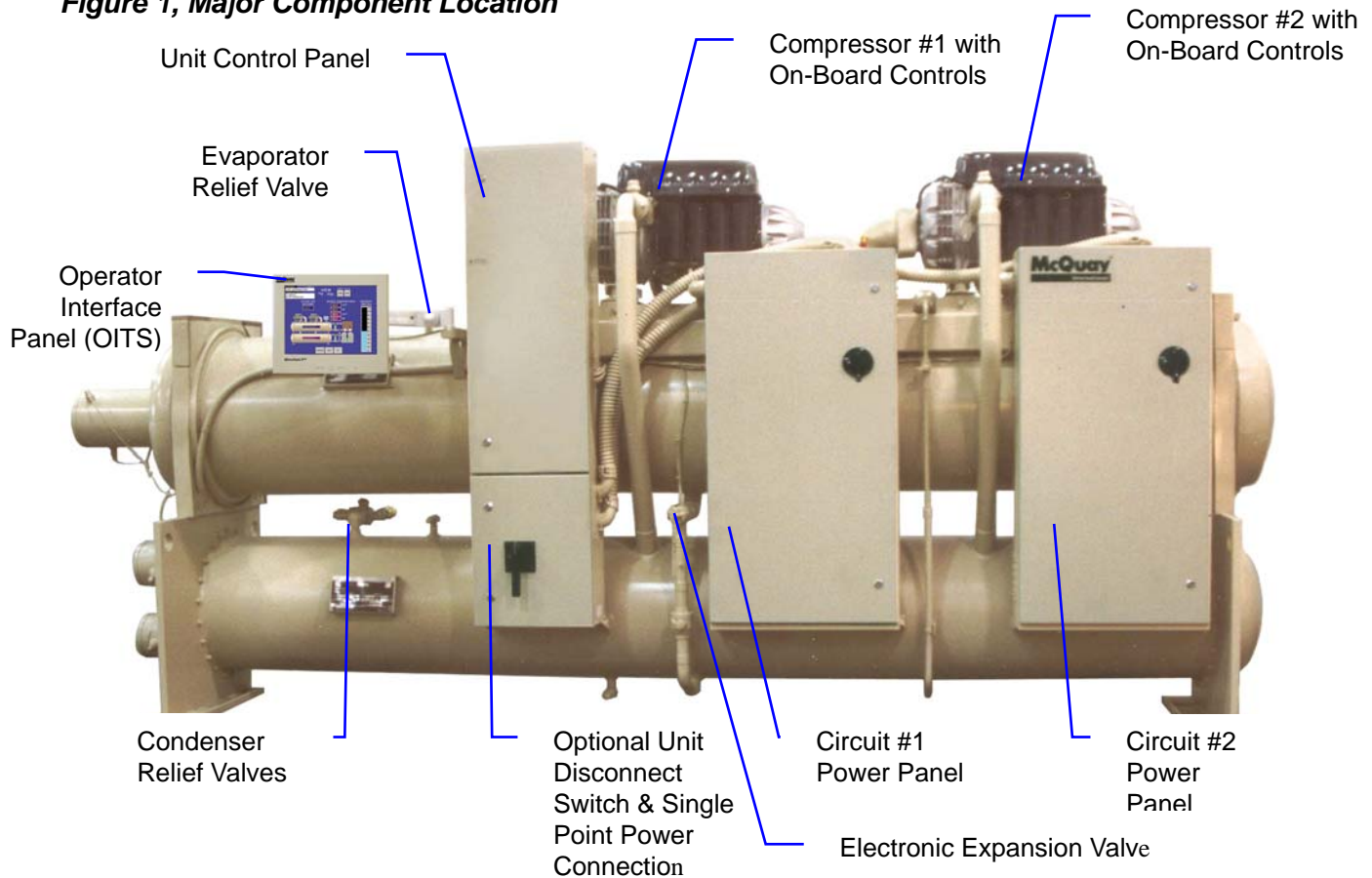

## General Description

The centrifugal MicroTech II control system consists of microprocessor-based controllers in the control panel, as well as on-board the compressors, providing monitoring and control functions required for the controlled, efficient operation of the chiller. The system consists of the following components:

- Operator Interface Touch Screen (OITS), one per unit-provides unit information and is the primary setpoint input instrument. It has no control function.
- Unit Controller, one per chiller-controls unit functions and communicates with all other controllers. It is the secondary location for setpoint input if the OITS is inoperative. It is located in the control panel that is adjacent to the OITS Panel.
- Compressor Controller for each compressor-controls compressor functions. They are located in the control panel.
- On-board compressor controller mounted on each compressor that monitors compressor operation and controls bearing operation.

The operator can monitor all operating conditions by using the unit-mounted OITS. In addition to providing all normal operating controls, the MicroTech II control system monitors equipment protection devices on the unit and will take corrective action if the chiller is operating outside of its normal design conditions. If a fault condition develops, the controller will shut a compressor, or the entire unit, down and activate an alarm output. Important operating conditions at the time an alarm condition occurs are retained in the controller's memory to aid in troubleshooting and fault analysis.

The system is password protected and only allows access by authorized personnel. The operator must enter the password into the touch screen (or one of the controller's keypad) before any setpoints can be altered.

**NOTE:** It is important to understand that the OITS is the operator interface device under normal conditions. If, and only if, it is unavailable, should the unit controller be used to change setpoints or operate the chiller.

**Figure 2, Major Control Components**

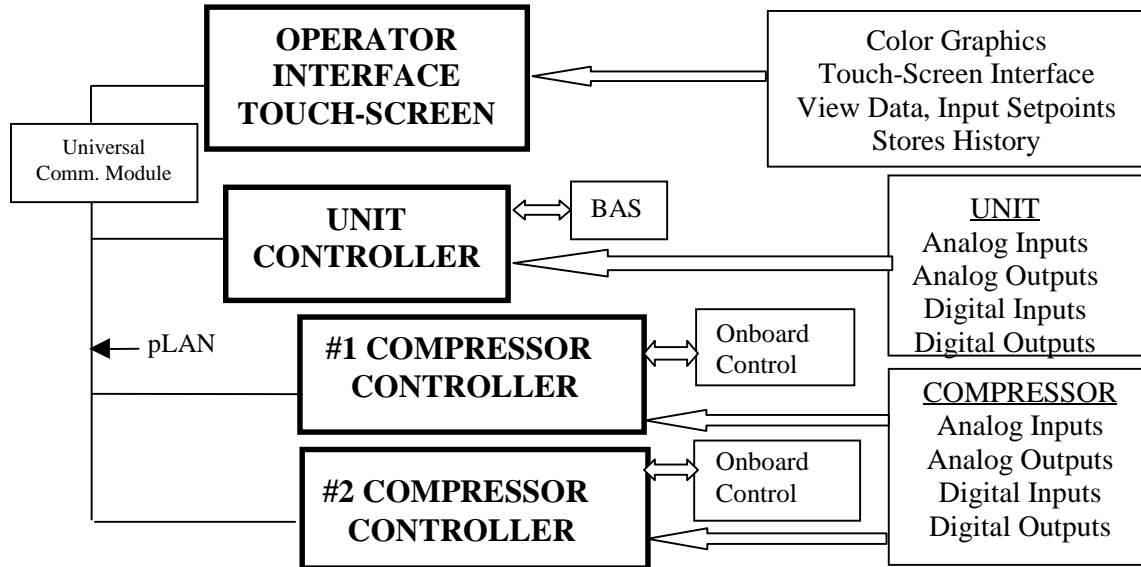

# Control Panel

The unit and compressor controllers along with unit and compressor on/off switches are mounted in the unit control panel which is mounted adjacent to the OITS panel. See Figure 1. The switches are designated “I” for on and “O” for off. The compressor on/off switch should only be used when an immediate stop is required since the normal shut down sequence is bypassed.

The switch panel also has a Circuit Breaker that interrupts power to the cooling tower fans, valves, and evaporator and condenser pumps, if any of these are tied into the MicroTech II controller for control of their operation. If these components operate independently from the chiller control, the breaker has no effect.

The unit controller's primary function is processing data relating to the entire chiller *unit* operation as compared to data relating to the *compressor* operation. The unit controller processes information and sends data to the compressor controllers and devices and relays information to the OITS for graphic display. It has a 4x20 LCD display and keys for accessing data and changing setpoints. The controller LCD can display most of the same information as the OITS and can operate the chiller independently if the OITS is not available.

**Figure 3, Control Panel Interior**

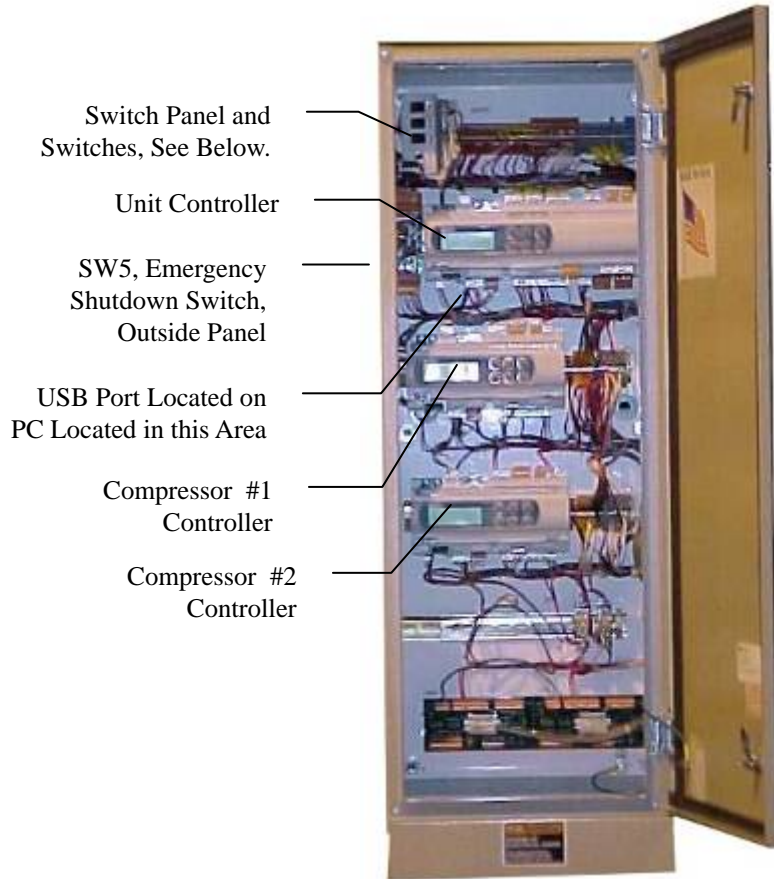

**Figure 4, Switch Locations**

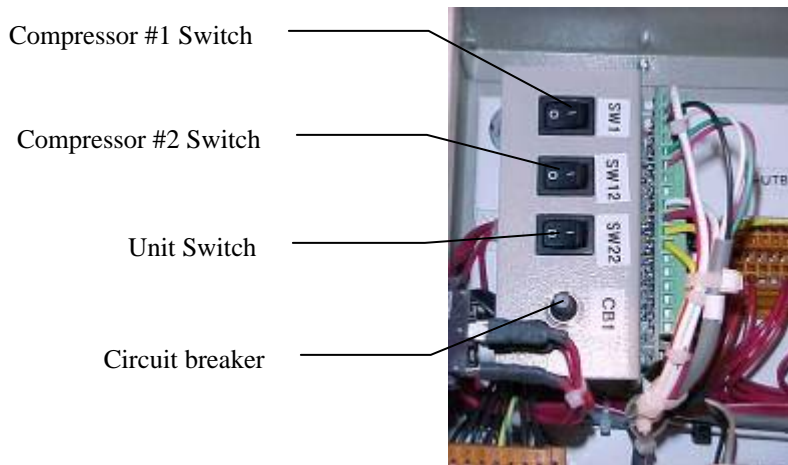

# Use with On-Site Generators

---

Magnitude chillers have their total tonnage divided between two compressors that start sequentially and they are operated with variable frequency drives. These features make Magnitude chillers especially appropriate for use in applications where they may be required to run with on-site electrical generators. This is particularly true when the generators are used for temporary power when the utility power is lost.

**Starting/Stopping Procedure:** The stopping of the chiller in the event of a power failure is typically uneventful. The chiller will sense a loss of voltage and the compressors will stop, coasting down using power generated from their dynamic braking to maintain the bearing magnetic field. The stop signal will initiate a three-minute stop-to-start timer, effectively preventing compressor restart for three minutes. The timer is adjustable from three to fifteen minutes, but the recommended and default value is three minutes. This interval allows the generator sufficient time to get up to speed and stabilize. The chiller will restart automatically when the start-to-start timer expires.

**Transfer Back to Grid Power:** Proper transfer from stand-by generator power back to grid power is essential to avoid compressor damage.

## WARNING

Stop the chiller before transferring supply power from the generator back to the utility power grid. Transferring power while the chiller is running can cause severe compressor damage.

The necessary procedure for reconnecting power from the generator back to the utility grid is show below. These procedures are not peculiar to McQuay units only, but should be observed for any chiller manufacturer.

1. Set the generator to always run five minutes longer than the unit start-to-start timer, which could be set from 15 to 60 minutes. The actual setting can be viewed on the operator interface panel on the Setpoint/Timer screen.
2. Configure the transfer switch, provided with the generator, to automatically shut down the chiller before transfer is made. The automatic shut-off function can be accomplished through a BAS interface or with the “remote on/off” wiring connection shown in Figure 10 on page 8. A start signal can be given anytime after the stop signal since the three-minute start-to-start timer will be in effect.

**Chiller Control Power:** For proper operation on standby power, the chiller control power must remain as factory-wired from a unit-mounted transformer. Do not supply chiller control power from an external power source because the chiller may not sense a loss of power and do a normal shutdown sequence.

# Sequence of Operation

---

## Start-up of Magnitude Compressors:

### “Next On” Status

If none of the “OFF” conditions are true, then all the MicroTech II compressor controls in a network of up to 2 units (four compressors) will pole the status of each to determine the one having “Next On” status, which is usually the compressor with the least starts. This takes about one minute.

### Evap (Evaporator) Pump Start

Once this is determined, the unit controller of the chiller with the “Next On” compressor (when there are two chillers) will start the evaporator pump and determine if there is load based on the water temperature. This is determined if the leaving evaporator water is above the “LWT Setpoint” plus “Startup Delta T”. If there is no load, based on the temperature, the unit is in the state of ‘Awaiting Load’.

### Interlock On

If there is load, the unit waits for the Evaporator Recirculation Timer period (default value of 30 seconds) and starts the Interlock Timer for 10 seconds.

### Cond (Condenser) Pump Start

After Interlock is confirmed, the controller starts the Condenser Pump and checks for condenser flow before starting the first compressor.

### Compressor Start

Starting the compressor is accomplished by setting the Demand to 25% of the MAX KW setpoint. When the actual rpm of the compressor exceeds 350 rpm, the demand setting is allowed to be governed by the normal control logic.

### Compressor Run

The compressor that is running will signal all other compressors when it reaches full load. Full load status is determined when *any* one of the following tests is true:

1. Percent RLA exceeds 100% or the Active-Amp-Limit from an external-limiting source.
2. Evap Saturation pressure drops below the Evap Hold-Loading pressure setpoint.
3. Actual compressor RPM exceeds 97% of Max RPM limit from compressor.

### Lag Compressor Staging

The “Next On” compressor, will initiate the following staging sequence when it receives a Full Load indication from the Lead compressor or all other running compressors in the case of a four compressor (two units) setup.

The lag compressor will start (Demand set to 25% of Max KW setpoint). When the actual RPM exceeds 350 rpm, the lead compressor will unload to 25% of the MAX KW setpoint. The lead compressor will maintain this demand setting for a time period set by the Step-Down timer (found in Set COMP1 SPs (8) ). When the Step-Down timer expires, both compressors should be nearly matched in capacity and can began amp balancing to share the load equally.

**Note:** If the “Next On” compressor is on another chiller, the controller will start that chiller’s evaporator and condenser pumps, if they are separate from the lead unit’s pumps. Only compressors on the same unit will unload the lead compressor before starting the lag compressor.

### Unloading compressors:

The setpoint of ‘Nominal Capacity’ is used for defining the point to unload a compressor on a single or two-chiller system. With each compressor having its ‘Nominal Capacity’ defined, then the network, which is load

balanced, continues to unload at 0.2 tenths or more below setpoint. Each compressor keeps computing the spare capacity of the network. When the designated ‘Next Off’ sees enough spare capacity, it will turn off. Then similarly, in about 40 seconds, a new compressor will be designated as the ‘Next Off’ and the spare capacity will continue to be calculated between the remaining compressors. Compressors continue to unload and stage off until there is only one compressor running. It will shut off when the water temperature reaches the LWT Setpoint minus the Shutdown Delta T.

## Multi-Chiller Setup

### Component Description

#### Communication Setup

The communication wiring and setup required for dual compressor operation is setup in the factory and should be reviewed when the chiller is initially started after installation or if there is any change made in the chiller control hardware.

RS485 communication wiring between chillers should be field wired before start-up and installed as a NEC Class 1 wiring system.

**Table 1, Address DIP Switch Settings for Controllers Using Multi-chiller communication**

Chiller	Comp 1	Comp 2	Unit Controller	Reserved	Operator Interface	Reserved
A	1	2	5	6	7	8
	100000	010000	101000	011000	111000	000100
B	9	10	13	14	15	16
	100100	010100	101100	011100	111100	000010

#### NOTES:

- Two Magnitude units can be interconnected.
- The interface setting is not a DIP switch setting. The ‘Operator Interface Touch Screen’ (OITS) address is selected by selecting the ‘service’ set screen. Then, with the Technician level password active, select the ‘pLAN Comm’ button. Buttons A(7), B(15), C(23), D(31) will appear in the middle of the screen, then select the letter for the OITS address for the chiller that it is on. Then close the screen. Note that A is the default setting from the factory.
- There are six Binary DIP Switches: Up is ‘On’, indicated by ‘1’. Down is ‘Off’, indicated by ‘0’. They are slide and not rocker switches. They are located on the upper-left corner of the face of the controller.

#### Operator Interface Touch Screen (OITS) Settings

Settings for any type of linked multiple compressor operation must be made to the MicroTech II controller. Settings on a dual compressor unit are made in the factory prior to shipment, but must be verified in the field before startup. Settings for multiple chiller installations are set in the field on the Operator Interface Touch Screen as follows:

Maximum Compressors ON – SETPOINTS - MODES screen, Selection #10 = 2 for a WMC, 4 for 2 WMCs.

Sequence and Staging – SETPOINTS - MODES screen, Selection #11 & #13; #12 & #14. Sequence sets the sequence in which compressors will start. Setting all to “1” evokes the automatic lead/lag feature and is the preferred setting.

Nominal Capacity – SETPOINTS - MOTOR screen, Selection #10. The setting is the compressor design tons. Compressors on dual units are always of equal capacity.

#### Communication Setup

- With no communication connections between chillers, disconnect control power and set the DIP switches as shown in Table 1.
- With all manual switches off, turn on control power to each chiller and set each OITS address (see Note 2 above).
- Verify correct nodes on each OITS Service Screen.

4. Connect chillers together (pLAN, RS485, between J6 connections on each unit's isolation boards. The boards are not furnished, separate RS485 isolators must be field supplied.

5. Verify correct nodes on each OITS Service Screen. See Figure 28 on page 52.

## Operating Limits:

Maximum standby ambient temperature, 130°F (55°C)

Minimum operating ambient temperature (standard), 35°F (2°C)

Leaving chilled water temperature, 36°F to 60°F (2.2°C to 15°C)

Maximum operating evaporator inlet fluid temperature, 66°F (19°C)

Maximum startup evaporator inlet fluid temperature, 90°F (32°C)

Maximum non-operating inlet fluid temperature, 100°F (38°C)

Minimum condenser water entering temperature, 55°F (12.8°C)

Maximum condenser entering temperature, 105°F (40.6°C)

Maximum condenser leaving temperature, 115°F (46.1°C)

## Low Condenser Water Temperature Operation

When the ambient wet bulb temperature is lower than design, the entering condenser water temperature can be allowed to fall to improve chiller performance. This is especially true of an advanced design such as the McQuay Magnitude chiller that features variable compressor speed.

It is an engineering fact that as the compressor discharge pressure is reduced, the amount of power to pump a given amount of gas also is reduced. The reduction can result in significant energy savings.

However, as with most centrifugal chiller applications, a tower bypass valve must be installed and must be controlled by the chiller MicroTech II controller. Figure 5 illustrates two temperature actuated tower bypass arrangements. The "Cold Weather" scheme provides better startup under cold ambient air temperature conditions. The check valve may be required to prevent entraining air at the pump inlet.

**Figure 5, Bypass, Mild Weather Operation**

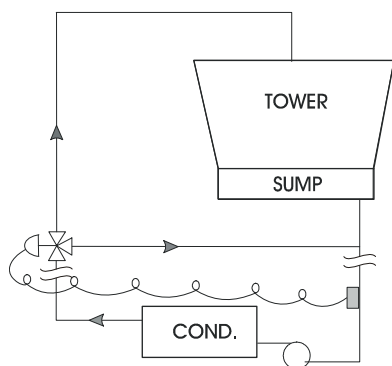

**Bypass, Cold Weather Operation**

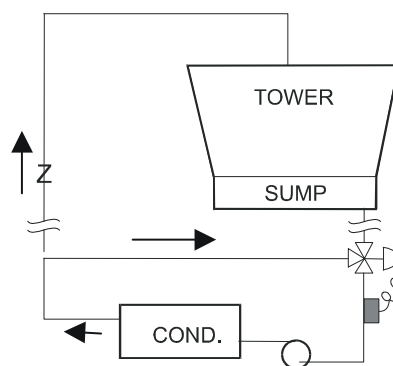

# Operating the Control System

---

## Interface Panel On/Off

The Operator Interface Panel is turned on and off with a switch located at the lower front of the panel. Screen control buttons are located to either side of it and elicit on-screen prompts when pressed.

The screen is equipped with a screen saver that blackens the screen. Touching the screen anywhere reactivates the screen. If the screen is black, touch it first to be sure it is on before using the ON/OFF button.

## Start/Stop Unit

There are four ways to start or stop the chiller. Three are shown below and selected in SETPOINT\MODE\SP3; the fourth way is through panel-mounted switches:

### 1. Operator Interface Panel (LOCAL)

Home Screen 1 has AUTO and STOP buttons that are only active when the unit is in "LOCAL CONTROL." This prevents the unit from being accidentally started or stopped when it is normally under control from a remote switch or BAS. When these buttons are pressed, the unit will cycle through its normal starting or stopping sequence.

### 2. Remote SWITCH

Selecting SWITCH in SP3 will put the unit under the control of a remote switch that must be wired into the control panel (see Figure 10 on page 8).

### 3. BAS

BAS input is field-wired into a module that is factory-installed on the unit controller.

## Control Panel Switches

The unit control panel, located adjacent to the Interface Panel, has switches inside the panel for stopping the entire unit or individual compressors. When the UNIT switch is placed in the OFF position, the chiller will shut down through the normal shutdown sequence whether one or two compressors are on.

The COMPRESSOR switches will immediately shut down the compressor without going through the shutdown sequence when placed in the OFF position. It is equivalent to an emergency stop switch.

## Change Setpoints

Setpoints are easily changed on the Operator Interface Touch Screen (OITS). A complete description of the procedure begins on page 40. Setpoints can also be changed in the unit controller, but this is not recommended except in an emergency when the OITS is unavailable.

## Alarms

A red ALARM light in the lower middle of any screen is illuminated if there is an alarm. If the optional remote alarm is wired in, it too will be energized.

There are three types of alarms:

- **Fault**, equipment protection alarms that shut a unit or compressor off.
- **Problem**, limit alarms that limit compressor loading in response to an out-of-normal condition. If the condition that caused a limit alarm is corrected, the alarm light will be cleared automatically.
- **Warning**, notification only, no action taken by controller.

Any type will light the ALARM light. Procedures for dealing with alarms are shown below:

1. Press the alarm light button. This will go directly to the ACTIVE ALARMS screen.
2. The alarm description (with date stamp) will be shown.
3. Press the ACKNOWLEDGE button to recognize the alarm.

4. Correct the condition causing the alarm.
5. Press the CLEAR button to clear the alarm from the controller. If the fault condition is not fixed, the alarm will continue to be on and the unit will not be able to be restarted.

## Component Failure

### Chiller Operation without the Operator Interface Panel

The Interface Panel communicates with the unit and compressor controllers, displaying data and transmitting touch screen inputs to the controllers. It does no actual controlling and the chiller can operate without it. Should the Touch Screen become inoperable, no commands are necessary for continuing unit operation. All normal inputs and outputs will remain functional. The unit controller can be used to view operational data, to clear alarms and to change setpoints, if necessary.

## Component Description

### Operator Interface Touch Screen

The operator interface touch screen (OITS) is the primary device for entering commands and entries into the control system. (Settings can also be made directly into the unit controller.) The OITS can also display controller data and information on a series of graphic screens. A single OITS is used per unit.

Selected information from the OITS panel can be downloaded via a USB port located in the unit control panel.

The OITS panel is mounted on a moveable arm to allow placement in a convenient position for the operator.

There is a screen-saver programed into the system. The screen is reactivated by touching it anywhere.

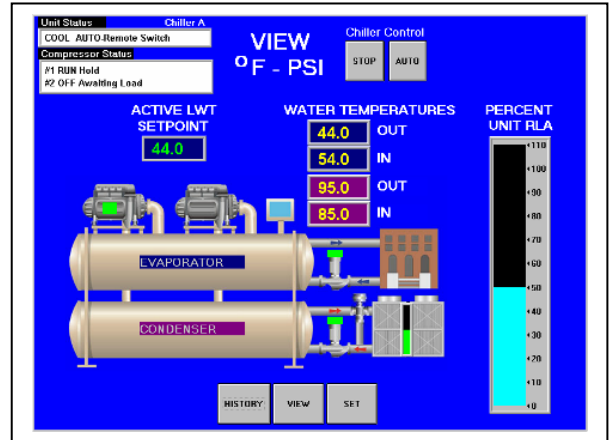

## Unit/Compressor Controller Description

### Hardware Structure

The controllers are fitted with a microprocessor for running the control program. There are terminals for connection to the controlled devices (for example: solenoid valves, tower fans, pumps). The program and settings are saved permanently in FLASH memory, preventing data loss in the event of power failure without requiring a back-up battery.

Each controller connects to other controllers, the on-board compressor microprocessors and the OITS via a local communications network. The unit controller can also have an optional module to provide communication for a BAS using standard open protocols.

## Keypad

A 4-line by 20-character/line liquid crystal display and 6-button keypad is mounted on the unit and compressor controllers. Its layout is shown below.

**Figure 6, Controller Keypad**

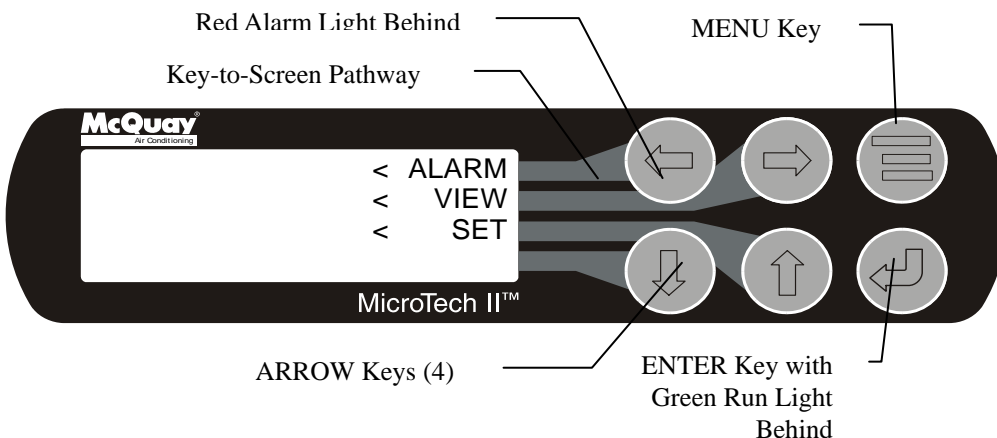

The four arrow keys (UP, DOWN, LEFT, RIGHT) have three modes of use:

- Scroll between data screens in the direction indicated by the arrows (default mode).
- Select a specific data screen in the menu matrix using dynamic labels on the right side of the display such as ALARM, VIEW, etc (this mode is entered by pressing the MENU key). For ease of use, a pathway connects the appropriate button to its respective label on the screen.
- Change field values in setpoint programming mode according to the following table:  
 LEFT key = Default                      RIGHT key = Cancel  
 UP key = Increase (+)                      DOWN key = Decrease (-)

These four programming functions are indicated by one-character abbreviation on the right side of the display. This programming mode is entered by pressing the ENTER key.

### Getting Started

There are two basic procedures to learn in order to utilize the MicroTech II controller:

1. Navigating through the menu matrix to reach a desired menu screen, and knowing where a particular screen is located.
2. Knowing what is contained in a menu screen and how to read that information, or how to change a setpoint contained in the menu screen.

## Navigating

The menus are arranged in a matrix of screens across a top horizontal row. Some of these top-level screens have sub-screens located under them. The location of each controller's screens can be found in the following table:

Controller	Screen Matrix	Screen Details
Unit	Page 58	Page 60
Compressor	Page 74	Not Applicable

There are two ways to navigate through the menu matrix to reach a desired menu screen.

- 1) One is to scroll through the matrix from one screen to another using the four ARROW keys.
- 2) Another way is to use shortcuts to work through the matrix hierarchy. From any menu screen,
  - a) Pressing the MENU key will take you to the top level of the hierarchy. The display will show ALARM, VIEW, and SET as shown in Figure 6. One of these choices can then be selected by pressing the key connected to it via the pathway shown in the figure.

- b) Depending on the top-level selected, a second level of screens will appear. For example, selecting ALARM will go the next level of menus under ALARM (ALARM LOG or ACTIVE ALARM). Selecting VIEW will go the next level of menus (VIEW COMPRESSOR STATUS, VIEW UNIT STATUS, VIEW EVAPORATOR, or VIEW CONDENSER). Selecting SET will go to a series of menus for looking at and changing setpoints.
- c) After selecting this second level, the desired screen can be acquired using the arrow keys. A typical final screen is shown below.

Pressing the MENU key from any menu screen will automatically return you to the MENU mode.

**Figure 7, Typical Menu Display and Keypad Layout**

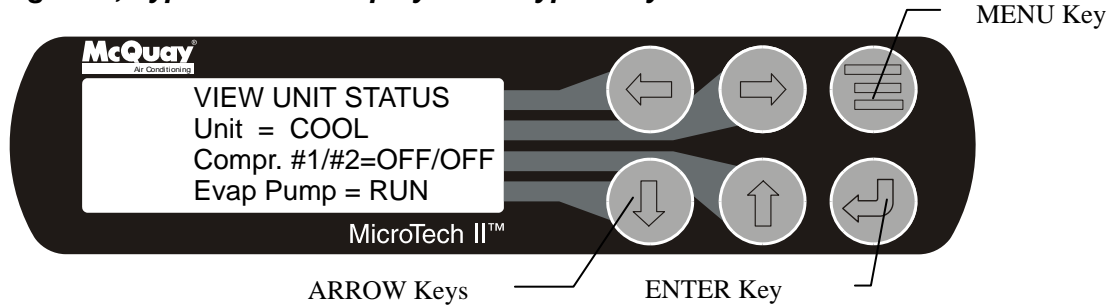

### Menu Screens

A hierarchical menu structure is used to access the various screens. Each menu screen can have one to four lines of information. Optionally, the last menu selection can access one of a set of screens that can be navigated with the UP/DOWN arrow keys (see the scrolled menu structure below). Menu selection is initiated by pressing the MENU key, which changes the display from a data screen to a menu screen. Menu selections are then made using the arrow keys according to labels on the right side of the display (the arrows are ignored). When the last menu item is selected, the display changes to the selected data screen. An example follows showing the selection of the “VIEW COMPRESSOR (n) screen. Suppose the initial screen is:

```
ALARM LOG
  (data)
  (data)
  (data)
```

After pressing the MENU button, the top-level menu screen will show:

```
< ALARM
< VIEW
< SET
<
```

After pressing the “VIEW” menu button, a menu screen will show:

```
VIEW < COMPRESSOR
      < UNIT
      < EVAPORATOR
      < CONDENSER
```

After pressing the “COMPRESSOR” menu button, the selected data screen will show;

```
VIEW COMP (n)
  (screen n data)
  (screen n data)
  (screen n data)
```

Where “n” is the number of the last viewed COMPRESSOR screen. The arrow keys will automatically return to the “scroll” mode at this time. Different compressor screens can then be selected with the UP/DOWN arrow keys.

# Unit Controller

**Table 2, Unit Controller, Analog Inputs**

#	Description	Signal Source	Range
1	Reset of Leaving Water Temperature	4-20 mA Current	0-(10 to 80°F)
2	Entering Evaporator Water Temperature	NTC Thermistor (10k@25°C)	-58 to 212°F
3	Entering Condenser Water Temperature	NTC Thermistor (10k@25°C)	-58 to 212°F
4	Leaving Condenser Water Temperature	NTC Thermistor (10k@25°C)	-58 to 212°F
5	Liquid Line Refrigerant Temperature	NTC Thermistor (10k@25°C)	-58 to 212°F
6	Demand Limit	4-20 mA Current	0-100 %RLA
7	Evaporator Water Flow	4 to 20 mA Current	0 to 10,000 gpm
8	Condenser Water Flow	4 to 20 mA Current	0 to 10,000 gpm
9	Refrigerant Leak Sensor	4 to 20 mA Current	0 to 100 ppm
10	Spare		

**Table 3, Unit Controller, Digital Inputs**

#	Description	Signal	Signal
1	Unit OFF Switch	0 VAC (Stop)	24 VAC (Auto)
2	Remote Start/Stop	0 VAC (Stop)	24 VAC (Start)
3	Not Used		
4	Evaporator Water Flow Switch	0 VAC (No Flow)	24 VAC (Flow)
5	Condenser Water Flow Switch	0 VAC (No Flow)	24 VAC (Flow)

**Table 4, Unit Controller, Digital Outputs**

#	Description	Load	Output OFF	Output ON
1	Evaporator Water Pump #1	Pump Contactor	Pump OFF	Pump ON
2	Evaporator Water Pump #2	Pump Contactor	Pump OFF	Pump ON
3	Condenser Water Pump #1	Pump Contactor	Pump OFF	Pump ON
4	Condenser Water Pump #2	Pump Contactor	Pump OFF	Pump ON
5	Tower Fan #1	Fan Contactor	Fan OFF	Fan ON
6	Tower Fan #2	Fan Contactor	Fan OFF	Fan ON
7	Spare			
8	Alarm	Alarm Indicator	Alarm OFF	Alarm ON
9	Tower Fan #3	Fan Contactor	Fan OFF	Fan ON
10	Tower Fan #4	Fan Contactor	Fan OFF	Fan ON

**Table 5, Unit Controller, Analog Outputs**

#	Description	Output Signal	Range
1	Cooling Tower Bypass Valve Position	0 to 10 VDC	0 to 100% Open
2	Cooling Tower VFD Speed	0 to 10 VDC	0 to 100%
3	EXV signal to IB Valve Control Bd.	0 to 10 VDC	0 to 100%
4	Y3 Electronic Expansion Valve	0 to 10 VDC	0 to 100% Open

## Unit Controller Setpoints

The following parameters are remembered during power off, are factory set to the **Default** value, and can be adjusted to any value in the **Range** column.

The “Type” column defines whether the setpoint is part of a coordinated set of duplicate setpoints in different controllers. There are three possibilities as given below:

**N** = Normal setpoint - Not copied from, or copied to, any other controller.

**M** = Master setpoint - Setpoint is copied to all controllers in the “Sent To” column.

**S** = Slave setpoint - Setpoint is a copy of the master setpoint (in the unit controller).

At power-up the slave node checks if the master node is operational and if so, it sets its copy of the setpoint equal to the master's. Otherwise, the setpoint remains unchanged. During normal operation, any time the master setpoint changes, the slave is updated as well.

The PW (password) column indicates the password that must be active in order to change the setpoint. Codes are as follows:

**O** = Operator, **M** = Manager, **T** = Technician (not available through the 4x20 display/keypad).

The following table groups setpoints that relate to the entire unit operation and are stored, for the most part, in the unit controller. All settings are made through the OITS, indiscriminately as to whether they are "unit" or "compressor."

**Table 6, Unit Controller Setpoints**

Description	Default	Range	Type	PW	Manual Reference
<b>Unit</b>					
Unit Enable	OFF	OFF, ON	M	O	Pg. 50
Control Source	KEYPAD	KEYPAD, BAS, DIGITAL INPUT	N	O	Pg. 50
Display Units	°F/psi	°F/psi, °C/kPa	N	O	--
Language	ENGLISH	ENGLISH, (TBD)	N	O	--
BAS Protocol	NONE	NONE, BACnet, LonWorks, MODBUS, N2	N	M	Pg. 50, Pg 76
<b>Leaving Water</b>					
Cool LWT	44. 0°F	40.0 to 80.0 °F	M	O	Pg. 11, Pg. 51
Startup Delta T	3.0°F	0.0 to 10.0 °F	M	O	Pg. 11, Pg. 51
Shutdown Delta T	3.0°F	0.0 to 3.0 °F	M	O	Pg. 11, Pg. 51
LWT Reset Type	NONE	NONE, RETURN, 4-20mA	N	M	Pg. 22
Max Reset Delta T	0.0°F	0.0 to 20.0 °F	N	M	Pg. 22
Start Reset Delta T	10. 0°F	0.0 to 20.0 °F	N	M	Pg. 22
<b>Timers</b>					
Evap Recirculate	30 sec	15 sec to 5 min	N	M	Pg. 5
<b>Pumps</b>					
Evap Pump	Pump #1 Only	Pump #1 Only, Pump #2 Only, Auto Lead, #1 Primary, #2 Primary	N	M	Pg. 65
Cond Pump	Pump #1 Only	Pump #1 Only, Pump #2 Only, Auto Lead, #1 Primary, #2 Primary	N	M	Pg. 65
<b>Cooling Tower</b>					
Tower Control	None	None, Temperature, Lift	N	M	Pg. 46
Tower Stages	2	1 to 4	N	M	Pg. 46
Stage Up Time	2 min	1 to 60 min	N	M	Pg. 46
Stage Down Time	5 min	1 to 60 min	N	M	Pg. 46
Stage Differential (Temp)	3.0 °F	1.0 to 10.0 °F	N	M	Pg. 46
Stage Differential (Lift)	6.0 psi	1.0 to 20.0 psi	N	M	Pg. 46
Stage #1 On (Temp)	70 °F	40 to 120 °F	N	M	Pg. 46
Stage #2 On (Temp)	75 °F	40 to 120 °F	N	M	Pg. 46
Stage #3 On (Temp)	80 °F	40 to 120 °F	N	M	Pg. 46
Stage #4 On (Temp)	85 °F	40 to 120 °F	N	M	Pg. 46
Stage #1 On (Lift)	35 psi	10 to 130 psi	N	M	Pg. 46
Stage #2 On (Lift)	45 psi	10 to 130 psi	N	M	Pg. 46
Stage #3 On (Lift)	55 psi	10 to 130 psi	N	M	Pg. 46
Stage #4 On (Lift)	65 psi	10 to 130 psi	N	M	Pg. 46
<b>Cooling Tower Valve / VFD</b>					
Valve/VFD Control	None	None, Valve Setpoint, Valve Stage, VFD Stage, Valve SP/VFD Stage	N	M	Pg. 46
Valve Setpoint (Temp)	65 °F	40 to 120 °F	N	M	Pg. 46
Valve Setpoint (Lift)	30 psi	10 to 130 psi	N	M	Pg. 46
Valve Deadband (Temp)	2.0 °F	1.0 to 10.0 °F	N	M	Pg. 46
Valve Deadband (Lift)	4.0 psi	1.0 to 20.0 psi	N	M	Pg. 46

Continued on next page

Description	Default	Range	Type	PW	Manual Reference
Stage Down @	20%	0 to 100%	N	M	Pg. 46
Stage Up @	80%	0 to 100%	N	M	Pg. 46
Valve Control Range (Min)	10%	0 to 100%	N	M	Pg. 46
Valve Control Range(Max)	90%	0 to 100%	N	M	Pg. 46
Valve Type	NC (To Tower)	NC, NO	N	M	Pg. 46
Minimum Start Position	0%	0 to 100%	N	M	Pg. 46
Minimum Position @	60 °F	0 to 100 °F	N	M	Pg. 46
Maximum Start Position	100%	0 to 100%	N	M	Pg. 46
Maximum Position @	90 °F	0 to 100 °F	N	M	Pg. 46
Error Gain	25	10 to 99	N	M	Pg. 46
Slope Gain	25	10 to 99	N	M	Pg. 46

These setpoints are normally viewed or changed on the OITS.

## Faults, Problems, Warnings

### Faults (Equipment Protection Shutdowns)

There are no Unit protection shutdown alarms; all such alarms are handled through the compressor controllers.

### Problems (Limit Alarms)

The following alarms limit operation of the chiller in some way as described in the Action Taken column.

**Table 7, Unit Controller Limit Alarms**

Description	Occurs When:	Action Taken	Reset
Evaporator Pump #1 Fault	No flow indicated for (5 sec) with Evaporator Pump #1 ON AND [the other pump is available (per the Evap Pump SP) AND has not faulted]	Start pump #2	Manual
Evaporator Pump #2 Fault	No flow indicated for (5 sec) with Evaporator Pump #2 ON AND [the other pump is available (per the Evap Pump SP) AND has not faulted]	Start pump #1	Manual
Condenser Pump #1 Fault	No flow indicated for (5 sec) with Condenser Pump #1 ON AND [the other pump is available (per the Evap Pump SP) AND has not faulted]	Start pump #2	Manual
Condenser Pump #2 Fault	No flow indicated for (5 sec) with Condenser Pump #2 ON AND [the other pump is available (per the Evap Pump SP) AND has not faulted]	Start pump #1	Manual
Entering Evaporator Water Temperature Sensor Fault	Sensor fault AND leaving water reset is based on entering water	Reset mode is set to No Reset	Manual. (Reset mode goes back to Entering Water)

### Warnings

The following “alarms” only generate a warning message to the operator. Chiller operation is not affected.

**Table 8, Unit Controller Warnings**

Description	Occurs When:	Action Taken	Reset
Entering Evaporator Temperature Sensor Fault	Sensor is open or shorted	Annunciation	Automatic
Entering Condenser Temperature Sensor Fault	Sensor is open or shorted	Annunciation	Automatic
Leaving Condenser Temperature Sensor Fault	Sensor is open or shorted	Annunciation	Automatic
Liquid Line Refrigerant Temperature Sensor Fault	Sensor is open or shorted	Annunciation	Automatic

## Unit Controller Functions

### Leaving Water Temperature (LWT) Reset

The Active Leaving Water variable shall be set to the current Leaving Water Temperature (LWT) setpoint unless modified by one of the reset methods below. (The current LWT setpoint is Cool LWT as determined by the chiller mode.) The type of reset in effect is determined by the LWT Reset Type setpoint.

#### Reset Type – NONE

The Active Leaving Water variable is set equal to the current LWT setpoint.

#### Reset Type – RETURN

The Active Leaving Water variable is adjusted by the return water temperature.

When the chiller mode = COOL, the Active Leaving Water variable is reset using the following parameters:

1. Cool LWT setpoint
2. Max Reset Delta T setpoint
3. Start Reset Delta T setpoint

Reset is accomplished by changing the Active Leaving Water variable from the (Cool LWT setpoint) to the (Cool LWT setpoint + Max Reset Delta T setpoint) when the evaporator (return – leaving) water temperature delta varies from the (Start Reset Delta T setpoint) to 0.

The Active Leaving Water variable is set equal to the Cool LWT setpoint if the reset signal is less than or equal to 4 mA. It is set equal to (Cool LWT setpoint + Max Reset Delta T setpoint) if the reset signal equals or exceeds 20 mA. The Active Leaving Water variable will vary linearly between these extremes if the reset signal is between 4 mA and 20 mA. An example of this action is shown below.

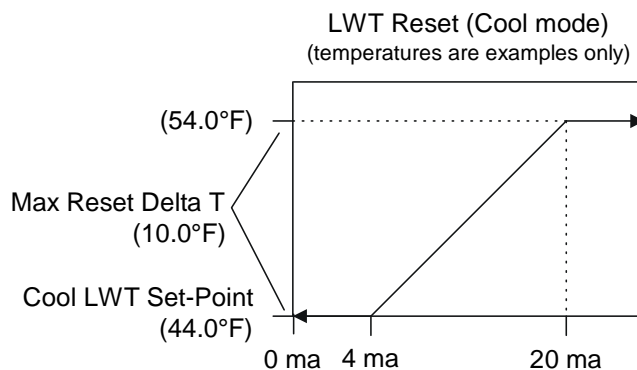

# Compressor Controller

The compressor controller's primary function is controlling and protecting the compressor. No setpoints are input to it. There is one compressor controller for each compressor on the unit. The compressor controller receives, processes, and sends data to the unit controller, the compressor on-board microprocessors and to external devices. With some operator intervention the compressor controller can operate the compressor if the operator interface touch screen is unavailable. Inputs and outputs are as follows:

**Table 9, Compressor Controller, Analog Inputs**

#	Description	Signal Source	Range
1	Leaving Evaporator Water Temperature	NTC Thermistor (10k@25°C)	-58 to 212°F
2	Spare		
3	Motor Current	0 to 5 VDC	0 to 125% RLA

**Table 10, Compressor Controller, Digital Inputs**

#	Description	Signal	Signal
1	Manual Off	0 VAC (Off)	24 VAC (Auto)
2	Spare		
3	Spare		
4	Spare		
5	Spare		
6	Spare		
7	Evaporator Water Flow Switch	0 VAC (No Flow)	24 VAC (Flow)
8	Condenser Water Flow Switch	0 VAC (No Flow)	24 VAC (Flow)
9	Spare		

**Table 11, Compressor Controller, Analog Outputs**

#	Description	Output Signal	Range
1	Spare		

**Table 12, Compressor Controller, Digital Outputs**

#	Description	Load	Output OFF	Output ON
1	Compressor Off Emer.	Solenoid	Circuit Breaker ON	Circuit Breaker OFF
2	Spare			
3	Spare			
4	Spare			
5	Spare			
6	Spare			
7	Spare			
8	Inter Lock	Solenoid	Comp Disabled OFF	Comp. Enabled ON
9	Spare			

# Compressor Controller Setpoints

The following parameters in Table 13 are remembered during power off, are factory set to the **Default** value and can be adjusted to any value in the **Range** column.

The “**Type**” column defines whether the setpoint is part of a coordinated set of duplicate setpoints in different controllers. The possibilities are given below:

- **N** = Normal setpoint - Not copied from or to any other controller.
- **D** = Duplicate setpoint. Setpoint is duplicated (same value) in all compressor controllers on the same chiller.
- **G** = Group setpoint. Setpoint is duplicated (same value) in all compressor controllers on all chillers in a group.
- **M** = Master setpoint - Setpoint is copied to all controllers in the “Sent To” column.
  - **S** = Slave setpoint - Setpoint is a copy of the master setpoint (in the Unit controller).

At power-up the slave controller checks if the master is operational and if so, it sets its copy of the setpoint equal to the master’s. Otherwise, the setpoint remains unchanged. During normal operation, any time the master setpoint changes, the slave is updated as well.

The **PW** (password) column indicates the password that must be active in order to change the setpoint. Codes are as follows:

**O** = Operator, **M** = Manager, **T** = Technician (not available through the 4x20 display/keypad)

The following table groups setpoints that relate to compressor operation and are stored, for the most part, in the compressor controllers. All settings are made through the OITS, indiscriminately as to whether they are “unit” or “compressor.”

**Table 13, Compressor Controller Setpoints**

Description	Default	Range	Type	PW	Manual Reference
<b>Motor Amps</b>					
Demand Limit	OFF	OFF, ON	N	O	
Minimum Amps	40%	20 to 80%	N	T	
Maximum Amps	100%	40 to 100%	N	T	
Soft Load	OFF	OFF, ON	D	M	
Begin Amp Limit	40%	20 to 100%	N	M	
Soft Load Ramp	5 min	1 to 60 min	D	M	
Maximum Rate	0.5 °F/min	0.1 to 5.0 °F/min	D	M	
Minimum Rate	0.1 °F/min	0.0 to 5.0 °F/min	D	M	
<b>Staging</b>					
Mode	Normal	Normal, Efficiency, Pump, Standby	N	M	
Sequence #	1	1,2, ... (# of Compressors)	N	M	
Maximum Compressors ON	16	1-16	G	M	
Stage Delta T	1.0	0.5-5.0	G	M	
Full Load	120 sec	30 to 300 sec	N	T	
Absolute Capacity	100 Tons	0 to 9999 Tons	D	T	
<b>Timers</b>					
Start-Start	40 min	15 to 60 min	N	M	
Stop-Start	3 min	3 to 20 min	N	M	
Source No Start	70 °F	50 to 100 °F	D	T	

Continued next page.

Description	Default	Range	Type	PW	Manual
-------------	---------	-------	------	----	--------

					Reference
<b>Alarms</b>					
Evaporator Freeze	34.0 °F	-9.0 to 45.0 °F	D	T	
Condenser Freeze	34.0 °F	-9.0 to 45.0 °F	D	T	
Low Evap Pressure	26 psi	10 to 45 psi	D	T	
Low Evap Pressure-Inhibit	38 psi	20 to 45 psi	D	T	
Low Evap Pressure-Unload	31 psi	20 to 45 psi	D	T	
High Discharge Temperature-Shutdown	190 °F	120 to 240 °F	N	T	
High Discharge Temperature-Load	170 °F	120 to 240 °F	N	T	
High Condenser Pressure	140 psi	120 to 240 psi	D	T	
Motor Current Threshold	10%	1 to 20%	N	T	
Surge High Suction SH - Start	50 °F	25 to 90 °F	N	T	
Surge High Suction SH - Run	25 °F	5 to 45 °F	N	T	
<b>Service</b>					
Vane Mode	AUTO	AUTO, MANUAL	N	T	
Unload Timer	10 sec	10 to 240 sec	N	T	
STOP Timer	1 sec	1 to 240 sec	N	T	

These setpoints are normally viewed or changed on the OITS, but can be changed on the unit controller if the OITS is not available.

## Compressor Faults, Problems, Warnings

### Faults (Equipment Protection Shutdowns)

Equipment protection faults cause rapid compressor shutdown. The compressor is stopped immediately (if the compressor was running).

The following table identifies each alarm, gives the condition that causes the alarm to occur, and states the action taken because of the alarm. All equipment protection alarms require a manual reset.

**Table 14, Compressor Controller Faults (Equipment Protection Shutdowns)**

Description	Occurs When:	Action Taken
Low Evaporator Pressure	Evaporator Press < Low Evap Pressure SP	Rapid Stop
High Condenser Pressure	Cond Press > High Condenser Pressure SP	Rapid Stop
Low Motor Current	I < Motor Current Threshold with Compressor ON for 30 sec	Rapid Stop
High Discharge Temperature	Temp > High Discharge Temperature SP	Rapid Stop
Mechanical High Pressure	Digital Input = High Pressure	Rapid Stop
High Motor Temperature	Digital Input = High Temperature	Rapid Stop
Surge High Suct SH-Starting	Temp > Surge High Suct SH-Start SP during first 5 minutes of Compressor ON	Rapid Stop
Surge High Suct SH-Running	Temp > Surge High Suct SH-Run SP after first 5 minutes of Compressor ON	Rapid Stop
No Compressor Stop	%RLA > Motor Current Threshold SP with Compressor OFF for 30 sec	Annunciation
Starter Fault	Starter Fault Digital Input = Fault AND Compressor State = START, INTLOK, RUN, or UNLOAD	Rapid Stop
Leaving Evaporator Water Temperature Sensor Fault	Sensor shorted or open	Rapid Stop
Evaporator Pressure Sensor Fault	Sensor shorted or open	Rapid Stop
Condenser Pressure Sensor Fault	Sensor shorted or open	Rapid Stop
Suction Temperature Sensor Fault	Sensor shorted or open	Rapid Stop
Discharge Temperature Sensor Fault	Sensor shorted or open	Rapid Stop
Evaporator Water Flow Loss	Evaporator Flow DI = No Flow for > 10 sec	Rapid Stop
Condenser Water Flow Loss	Condenser Flow DI = No Flow for > 10 sec	Rapid Stop

### Compressor Controller Events (Limit Alarms)

The following alarms do not cause compressor shutdown but limit operation of the chiller as described in the Action Taken column.

**Table 15, Compressor Controller Events**

Description	Occurs When:	Action Taken	Automatic Reset
Low Evaporator Pressure – Inhibit Loading	Pressure < Low Evap Pressure–Inhibit setpoint	Inhibit loading	Evap Press rises above (SP + 3psi)
Low Evaporator Pressure – Unload	Pressure < Low Evap Pressure–Unload setpoint	Unload	Evap Press rises above (SP + 3psi)
Evaporator Freeze Protect	Evap Sat Refr Temp < Evaporator Freeze setpoint	Start evaporator pump	Temp > (Evaporator Freeze SP + 2°F)
Condenser Freeze Protect	Cond Sat Refr Temp < Condenser Freeze Setpoint	Start condenser pump	Temp > (Condenser Freeze SP + 2°F)
High Discharge Temperature	Temperature > High Discharge Temperature-Load SP AND Suction superheat < 15°F	Load	Temp < (High Dsch Temp Load SP – 3°F) OR Superheat > 18°F

## Warnings

Warnings advise that a non-catastrophic problem exists, such as failed temperature sensor that provides a signal for information, not control purposes. There are no Warnings associated with the compressor controllers.

## Compressor Controller Functions

Each compressor determines if it has reached its maximum capacity (or maximum allowed capacity) and if so, set its Full Load flag. The flag is based on a number of conditions.

### Absolute Capacity

Each compressor estimates its absolute capacity from the present value of % RLA and the Absolute Capacity setpoint from the equation:

Absolute Capacity = (%RLA Factor) \* (Absolute Capacity setpoint)  
 where the %RLA Factor is interpolated from the following table.

%RLA	0	50	75	100	150
%RLA Factor	0	0.35	0.75	1.00	1.50

### Multiple Compressor Staging

This section defines which compressor is the next one to start or stop. The next section defines when the start, or stop, is to occur.

#### Functions

1. Can start/stop compressors according to an operator defined sequence.
2. Can start compressors based on the number of starts (run hours if starts are equal) and stop on run hours.
3. The above two modes can be combined so that there are two or more groups where all compressors in the first group are started (based on number of starts/hours) before any in the second group, etc. Conversely, all compressors in a group are stopped (based on run hours) before any in the preceding group, etc.
4. An “efficiency priority” mode can be selected for two or more chillers where one compressor is started on each chiller in the group before a second is started on any of them.
5. A “pump priority” mode can be selected for one or more chillers where all compressors on a given chiller are started before going to the next chiller in the group.
6. One or more compressor can be defined as “standby” where it is never used unless one of the normal compressors is unavailable.

#### Required Parameters

1. Sequence number setpoint (SQ#\_SP) for all compressors. Possible settings = (1-4).
2. Compressor Staging Mode setpoint (CSM\_SP) for all compressors. Possible settings are:

- NORMAL
  - EFFICIENCY PRIORITY
  - PUMP PRIORITY
  - STANDBY
3. Maximum Number of compressors ON setpoint (MAX\_ON\_SP). Possible settings = (1-4). This setpoint is the same for all compressors.
  4. Number of starts for all compressors.
  5. Number of run hours for all compressors.
  6. Status of all compressors (On-line, Available/Unavailable, Starting, Running, etc.)

**Configuration Rules**

1. Each standby compressor must have a sequence number greater than or equal to all non-standby compressors for which it is in standby.
2. All compressors in an “efficiency priority” or “pump priority” group must be set to the same sequence number.

## Compressor State Control (Comp State)

Operation of the compressor is controlled by the state-transition diagram shown below. A state variable (Comp State) shall be used to maintain the current state (OFF, START, INTLCK, RUN, UNLOAD, or STOP). Transitions from one state to another are controlled by the condition statements in the **TEST** boxes. **TASK** boxes indicate actions that must be performed.

**Figure 8, Compressor State**

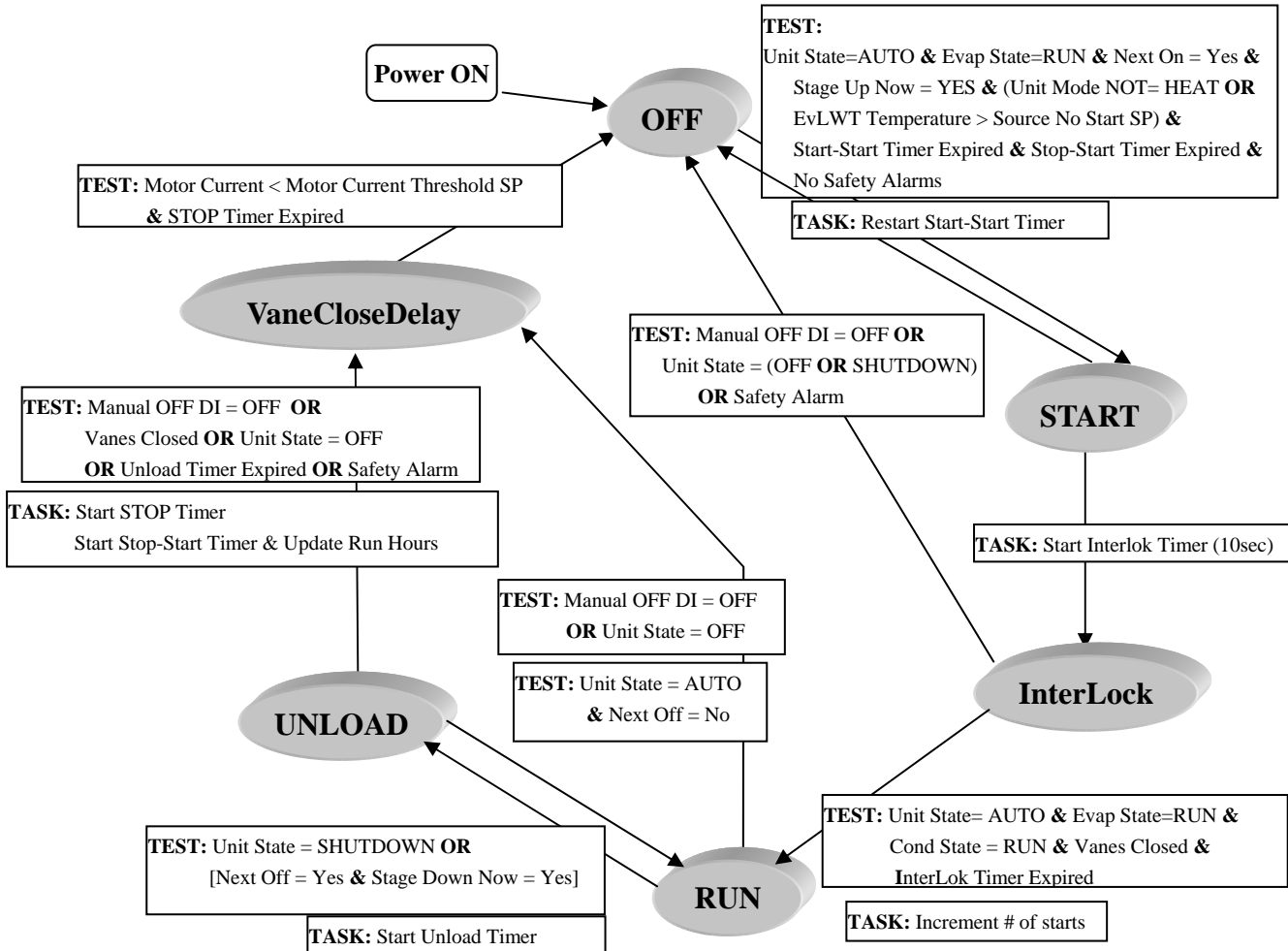

## Compressor Capacity Control

### Leaving Water Control Mode

Compressor capacity is determined by the status of the leaving chilled water temperature (LWT), which is a direct indicator of whether the chiller is producing enough cooling to satisfy the cooling load. The LWT is compared to the active chilled water setpoint, and compressor loading or unloading ensues, considering any capacity overrides that may be in effect.

### Capacity Overrides

The conditions described in the following subparagraphs override normal capacity control when the chiller is in the COOL mode. These overrides are not in effect for loading and unloading when the Vane Mode is set to MANUAL. Of the following limits, the one creating the lowest amp limit is in effect. The resulting present limit value for compressor current is stored in the Active Demand Limit variable.

### **Low Evaporator Pressure**

If the evaporator pressure drops below the Low Evaporator Pressure – Inhibit setpoint, the unit will inhibit capacity increase. If the evaporator pressure drops below the Low Evaporator Pressure - Unload setpoint, the unit will begin capacity decrease.

### **High Discharge Temperature - Load**

If the discharge temperature rises above the High Discharge Temperature - Load setpoint and the motor current is < 50% RLA, the unit will begin capacity increase.

### **Soft Load**

Soft Loading is a configurable function used at compressor startup to limit the maximum current draw on the compressor in a ramp-up type manner. It is only active on the first compressor to start. The setpoints that control this function are:

- Soft Load – (ON/OFF)
- Begin Amp Limit – (%RLA)
- Maximum Amps – (%RLA)
- Soft Load Ramp – (seconds)

The active soft load limit value (in % RLA) increases linearly from the Begin Amp Limit setpoint to the Maximum Amps setpoint over the amount of time specified by the Soft Load Ramp setpoint. If the amp draw rises above the currently active soft load limit value, the unit will inhibit capacity increases. If the amp draw rises to 5% or more above this value, the unit will begin capacity decrease.

### **Maximum LWT Rate**

The maximum rate at which the leaving water temperature can drop (chiller mode = COOL) is limited at all times by the Maximum Rate setpoint. If the rate exceeds this setpoint, capacity increases is inhibited.

### **Demand Limit**

The maximum amp draw of the compressor can be limited by a 4 to 20 mA signal on the Demand Limit analog input. This function is only enabled if the Demand Limit setpoint is set to ON. The amp limit decreases linearly from the Maximum Amp Limit setpoint (at 4 mA) to the Minimum Amp Limit setpoint (at 20mA). If the amp draw rises above the limit value, the unit will inhibit capacity increases. If the amp draw rises to 5% or more above this value, the unit will begin capacity decrease.

### **Network Limit**

The maximum amp draw of the compressor can be limited by a value sent through a BAS network connection and stored in the Network Limit variable. If the amp draw rises above the limit value, the unit will inhibit capacity increases. If the amp draw rises to 5% or more above this value, the unit will begin capacity decrease.

### **Minimum Amp Limit**

The minimum amp draw of the compressor can be limited by the Minimum Amps setpoint. If the amp draw drops below the limit value, the unit will inhibit capacity decrease.

### **Maximum Amp Limit**

The maximum amp draw of the compressor is always limited by the Maximum Amps setpoint. This limit has priority over all other functions including manual capacity control. If the amp draw rises above the limit value, the unit will inhibit capacity increases. If the amp draw rises to 5% or more above this value, the unit will begin capacity decrease.

# Compressor On-Board Controllers

Each compressor is equipped with microprocessor controllers and sensors that provide control and data acquisition. The data is transmitted to other controllers and the OITS via the multi-unit communication network. The on-board controllers consist of:

- **Compressor Controller:** the compressor controller is the central processor of the compressor. It is continually updated with critical data from the motor/bearing controller and external sensors. An important function is to control the compressor speed and guide vanes operation in order to satisfy load requirements, to avoid surge and to provide for optimum efficiency. The controller monitors over 60 parameters, including:

Refrigerant pressures and temperatures	Line voltage
Phase failure detection	Motor temperature
Silicone Rectifier (SCR) temperature	Speed
Line currents	Guide vane position
- **Soft-Start Controller:** the soft-start controller limits current inrush by temporarily inserting a charging resistor between the ac line and the +DC bus. It works in conjunction with the variable-speed function.
- **Motor/Bearing Controller:** the motor/bearing system provides the measurements and control to calculate and maintain the desired shaft position. An RS-485 link connects the bearing controller and the compressor controller.
- **Backplane:** although not a controller, the backplane connects the on-board control modules with the soft-start controller, power electronics, motor cooling solenoids and pressure/temperature sensors.

**Figure 9, Compressor Electric/Electronic Components**

1. Rectifiers
2. Main Power Block
3. Soft Start Controller
4. Insulated-gate Bipolar Transistor I.G.B.T Inverter
5. High Voltage DC-DC Converter
6. Compressor, Bearing/Motor Controllers
7. Interstage pressure / temperature sensor
8. Suction Pressure / temperature sensor

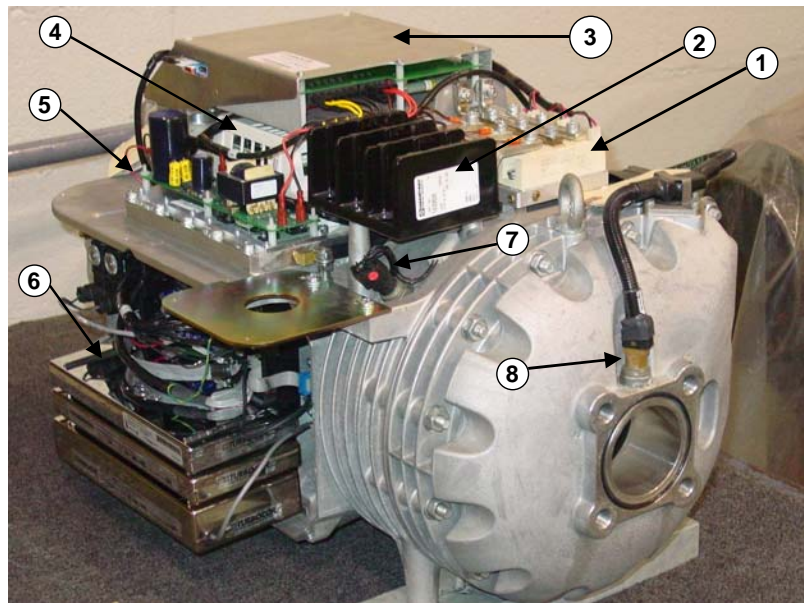

**Figure 10, Field Wiring Diagram**

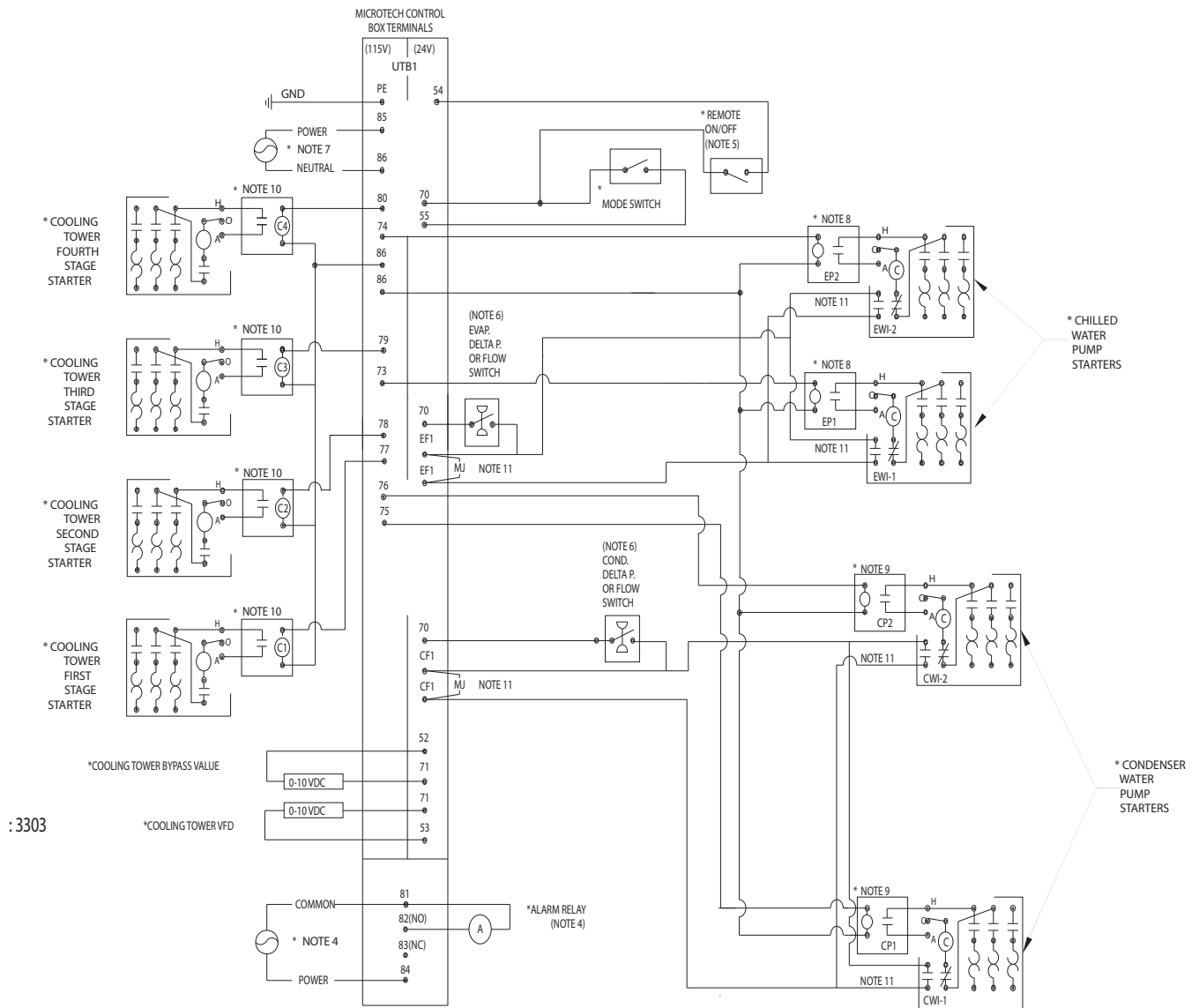

: 3303

EXCERPT FROM SCHEM. 330387903 REV. 0D  
FIELD CONNECTION DIAGRAM  
CENTRIFUGAL UNITS

FOR DC VOLTAGE AND 4-20 MA CONNECTIONS (SEE NOTE 3)  
FOR DETAILS OF CONTROL REFER TO UNIT CONTROL SCHEMATIC 330342103  
COMPRESSOR CONTROL SCHEMATIC 42203  
LEGEND: 330343003  
\* FIELD SUPPLIED ITEM

NOTE: Complete notes are on the following page.

## Field Wiring Diagram Notes

1. Compressor terminal boxes are factory-mounted and wired. All line-side wiring must be in accordance with the NEC and be made with copper wire and copper lugs only. Power wiring between the terminal box and compressor terminals is factory installed.
2. Minimum wire size for 115 VAC is 12 ga. for a maximum length of 50 feet. If greater than 50 feet refer to McQuay for recommended wire size minimum. Wire size for 24 VAC is 18 ga. All wiring to be installed as NEC Class 1 wiring system. All 24 VAC wiring must be run in separate conduit from 115 VAC wiring. Wiring must be wired in accordance with NEC and connection to be made with copper wire and copper lugs only.
3. Voltage unbalance not to exceed 2% with a resultant current unbalance of 6 to 10 times the voltage unbalance per NEMA MG-1, 1998 Standard. Supply voltage must be +/- 10% of compressor nameplate voltage.
4. A customer furnished 24 or 120 vac power for alarm relay coil may be connected between UTB1 terminals 84 power and 81 neutral of the control panel. For normally open contacts wire between 82 & 81. For normally closed wire between 83 & 81. The alarm is operator programmable. Maximum rating of the alarm relay coil is 25VA.
5. Remote on/off control of unit can be accomplished by installing a set of dry contacts between terminals 70 and 54.
6. If field supplied pressure differential switches are used, they must be installed across the vessel and not the pump. They must be suitable for 24 vac and low current application.
7. Customer supplied 115 VAC 20 amp power for optional evaporator and condenser water pump control power and tower fans is supplied to unit control terminals (UTB1) 85 power / 86 neutral, PE equipment ground.
8. Optional customer supplied 115 VAC, 25-VA maximum coil rated, chilled water pump relay (ep1 & 2) may be wired as shown. This option will cycle the chilled water pump in response to chiller demand.
9. The condenser water pump must cycle with the unit. A customer supplied 115 VAC 25 VA maximum coil rated, condenser water pump relay (CP1 & 2) is to be wired as shown. Units with free-cooling must have condenser water above 60°F before starting.
10. Optional customer supplied 115 VAC 25 VA maximum coil rated cooling tower fan relays (C1 - C2 standard, C3-C4 optional) may be wired as shown. This option will cycle the cooling tower fans in order to maintain unit head pressure.
11. Auxiliary 24 VAC rated contacts in both the chilled water and condenser water pump starters must be wired as shown.
12. 4-20mA external signal for chilled water reset are wired to terminals 71 and 51 on the unit controller; load limit is wired to terminals 71 and 58 on the unit controller.
13. Optional Control Inputs. The following 4-20 ma optional inputs are connected as shown:
  - Demand Limit; Terminals 58 and 71 common
  - Chilled Water Reset; Terminals 51 and 71 common
  - Evaporator Water Flow; Terminals 59 and 71 common
  - Condenser Water Flow; Terminals 60 and 71 common
14. Optional Control Power Source. 115 volt control power can be supplied from a separate circuit and fused at 20 amps inductive load. Connection is to terminals 85 and 86 common.
15. 4-20 mA external signal for chilled water reset are wired to terminals 71 and 51 on the unit controller; load limit is wired to terminals 71 and 58 on the unit controller.

## Interface Touch Screen

---

### Navigation

The home-view screen shown on page 34 is usually left on (there is a screen-saver built in that is reactivated by touching the screen anywhere). This VIEW screen contains the STOP and AUTO buttons used to start and stop the unit when in Local control. Other groups of screens can be accessed from the Home screen by pressing one of three buttons on the bottom of the screen: HISTORY, VIEW, SET.

- HISTORY will go to the last history screens viewed and can toggle between the two history screens.
  - Trend History
  - Alarm History
- VIEW will go to the home View screen. Pressing again will go to the detail View screen used to look in detail at settings and the operation of the chiller. Pressing VIEW from any other screen will return to the last displayed View screen. A new button called MENU will appear when in the View mode. See page 37 for details.
- SET will go to the last Set screen used.

Figure 11 illustrates the arrangement of the various screens available on the OITS. A few minutes practice on an actual OITS should provide an acceptable level of confidence in navigating through the screens.

Figure 11, OITS Screen Layout

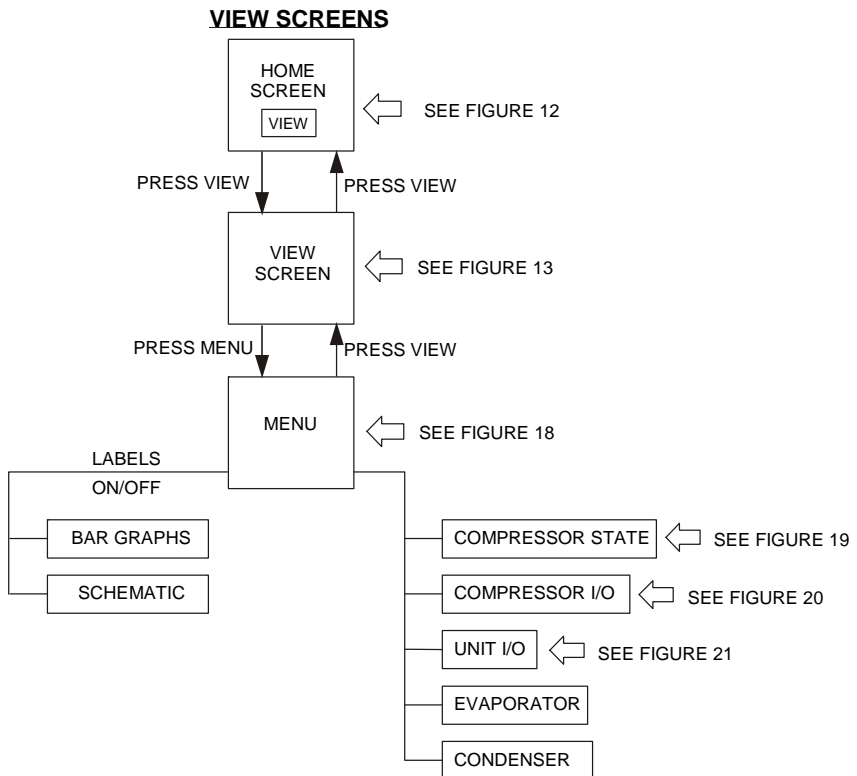
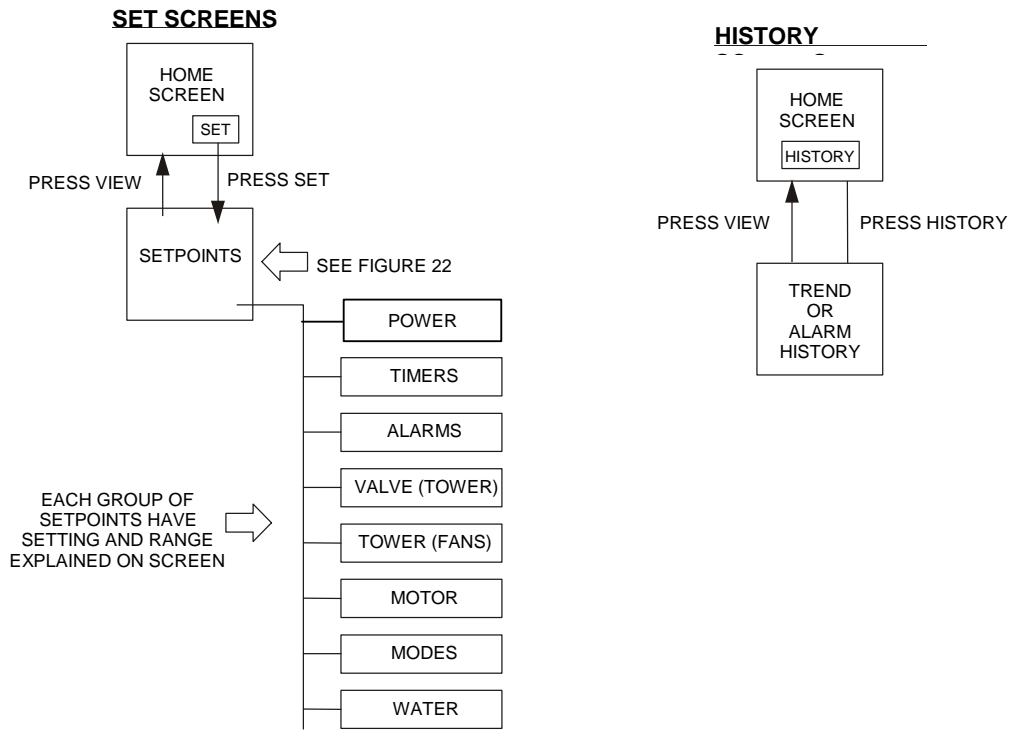

Pressing VIEW from any sub-menu will toggle back to the home  
 Pressing MENU when in any sub-menu will return to the view  
 Pressing SET or HISTORY will go to these groups of

# Screen Descriptions

Figure 12, Home View Screen

## VIEW Screens

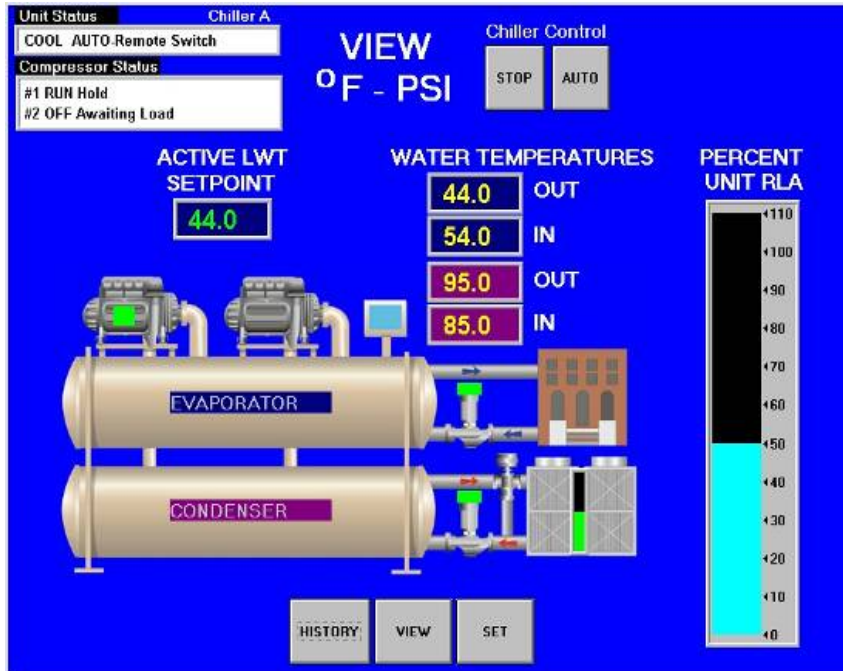

View screens are used for looking at unit status and conditions.

### Home View Screen

The Home View Screen shows the basic operating condition of the chiller and is the screen that is normally left on. Superimposed on a chiller schematic drawing is:

### Alarm

A red “ALARM” light will appear to the right of the “SET” button should an alarm occur. Pressing it will bring up the active alarm screen to view the alarm details.

### Information

- Chilled water setpoint (ACTIVE LWT SETPOINT)
- Entering and leaving chilled water temperatures

- Entering and leaving condenser water temperatures
- Percent motor amps
- UNIT STATUS is MODE followed by STATE followed by the SOURCE that is the device or signal that created the STATE. The possible combinations are in the following table:

Table 16, UNIT STATUS Combinations

MODES	STATES	SOURCES
COOL	OFF	Manual Switch
	SHUTDOWN (Note 1)	Remote Switch
	AUTO	Local
		BAS Network

Note 1: Shutdown is the state of shutting down; vane close, etc.

- COMPRESSOR STATUS is MODE followed by STATE followed by the SOURCE that is the device or signal that created the STATE. The possible combinations are in the following table:

Table 17, COMPRESSOR STATUS Possibilities

Complete STATUS Text (in priority sequence)	Notes
OFF Manual Switch	Reason for the compressor being off
OFF Compressor Alarm	
OFF Unit State	
OFF Evap Flow/Re-circulate	
OFF Start to Start Timer=xxx	
OFF Stop to Start Timer=xxx	
OFF Staging (Next ON)	
OFF Awaiting Load	
RUN Unload Vanes-Max Amps	Overrides water temperature command
RUN Hold Vanes-Max Amps	
RUN Manual Vanes & Speed	Used for service purposes; "T" password required; Operated

RUN Load Vanes-Manual Speed	from compressor controller
RUN Hold Vanes-Manual Speed	
RUN Unload Vanes-Manual Speed	
RUN Load Speed-Manual Vanes	
RUN Hold Speed-Manual Vanes	
RUN Unload Speed-Manual Vanes	
RUN Unload Vanes-Lag Start	Overrides water temperature command
RUN Hold Vanes-Evap Press	
RUN Unload Vanes-Evap Press	
RUN Unload Vanes-Soft Load	
RUN Hold Vanes-Soft Load	
RUN Load Vanes-Disch Temp	
RUN Hold Vanes-Pull-down Rate	
RUN Unload Vanes-Demand Limit	
RUN Hold Vanes-Min Amps	
RUN Load Vanes	
RUN Hold Vanes	
RUN Unload Vanes	
SHUTDOWN Unload	Unloading during the shutdown sequence

**NOTES:**

1. Timer countdown values will be shown where “(xxx)” is shown below.
2. “Vanes” or “Speed” is shown in the RUN state to indicate if the capacity is controlled by speed from the VFD or by vane control.

**Action Buttons for:**

- Chiller Control: normal start (AUTO button) and STOP button. The STOP button activates the normal shutdown sequence. These buttons are only active when the when control is in the "Local Control" mode. This eliminates the possibility of inadvertently shutting off the unit locally when it is under control of a remote signal such as a BAS.
- HISTORY, toggles between the Trend History screen and the Alarm History screen.
- SET, toggles between the Setpoints screen that are used for changing setpoints and the Service screen.

**Returning**

Pressing the VIEW button from any screen will return to this screen

Figure 13, Detail View Screen

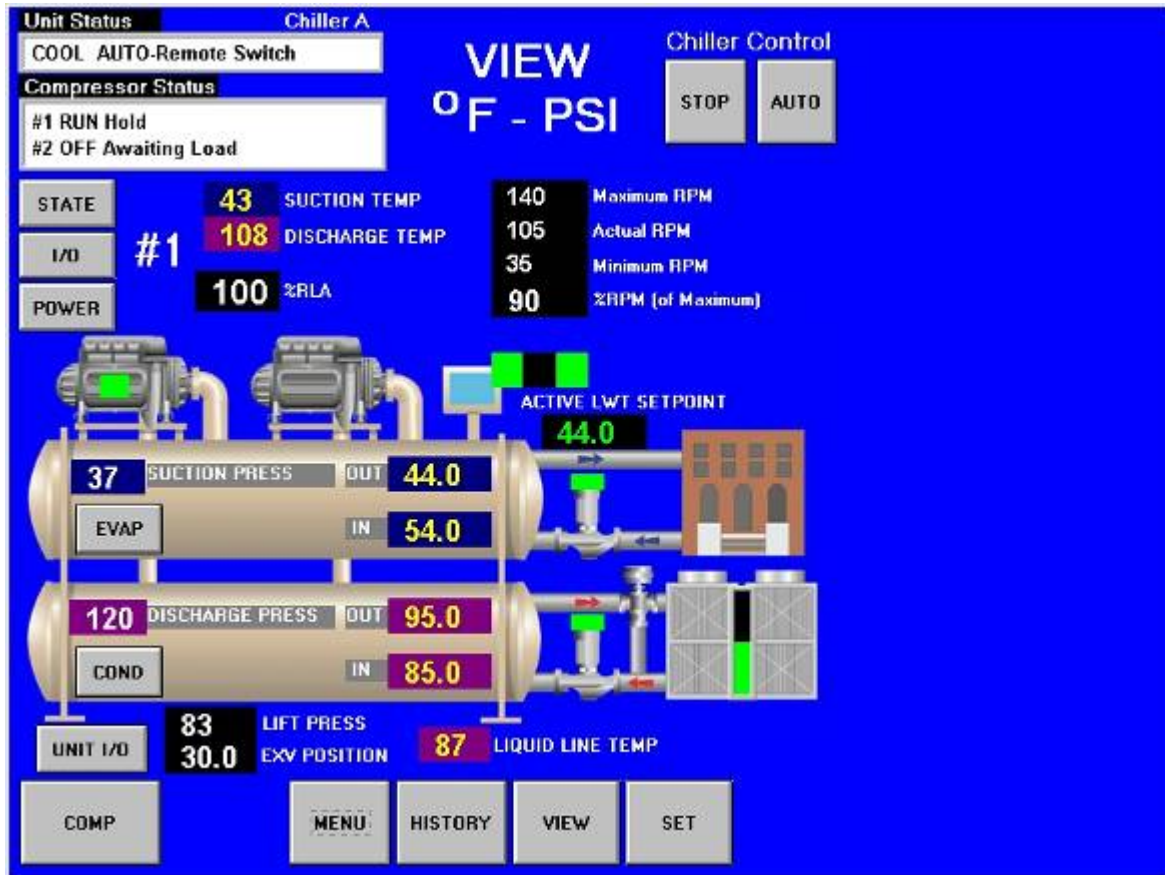

Data for one compressor is shown at a time on this screen. Pressing the COMPRESSOR button in the screen lower-left hand corner will toggle between #1 and #2 compressor.

Pressing the VIEW button on the bottom of the Home View screen accesses the Detail View Screen shown above. This screen gives additional information on the refrigerant pressures and temperatures.

Pressing the STATE button will bring up a display of the compressor state as described on page 37.

Pressing the I/O button displays the status of the compressor inputs and outputs as described in Figure 16 on the same page. Magnitude units will have a COMP button that will toggle between the two compressors' data, allowing the STATE and I/O detail screens to be viewed for either compressor.

Pressing the UNIT I/O button displays the unit inputs and outputs as described in Figure 17 on page 38.

Pressing the EVAP or COND button will give detailed information on the evaporator or condenser pressures and temperatures.

Pressing the ACTIVE LWT SETPOINT button will show a window from which the leaving water setpoints can be changed. However, it is recommended that the SETPOINT screens described later be used for this purpose.

Pressing the MENU button on the bottom of the screen will go to a menu (see Figure 14) from which the above listed screens can also be accessed.

This screen will be superimposed on the right side of the VIEW screen. This screen will remain visible until another display button (such as STATE, I/O, etc.) is pressed.

**Figure 14, View Menu**

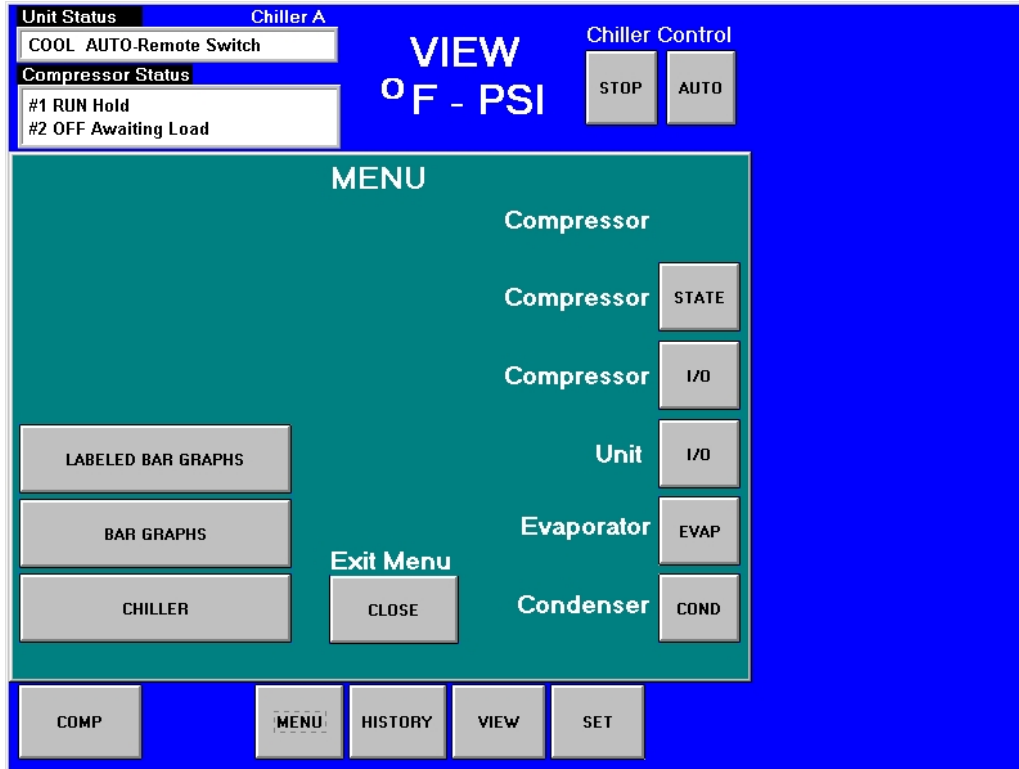

This View Menu is accessed by pressing the MENU button from the Detail View Screen. The menu screen accesses several informational screens as shown in the above figure.

**Figure 15, View Compressor State Screen**

For example, pressing the Compressor-State button on the Menu screen in Figure 14 will display the screen shown in Figure 15 on the right side of both the Menu screen and the Detail View screen. The Compressor State screen is basically a compilation of the events that the chiller sequences through at startup. A green light (light gray in the figure) indicates that a particular sequence requirement has been satisfied. It is recommended that this screen be viewed during the start up sequence. One can see the requirements light up as they are met and quickly see why a non-start may have occurred. For example, The Evap Flow OK will light when the evaporator flow switch is closed by flow.

The bottom sections (from "RUN" down) are in effect during the shut down process. The sequence transitions back to OFF at this point and the OFF light will be illuminated.

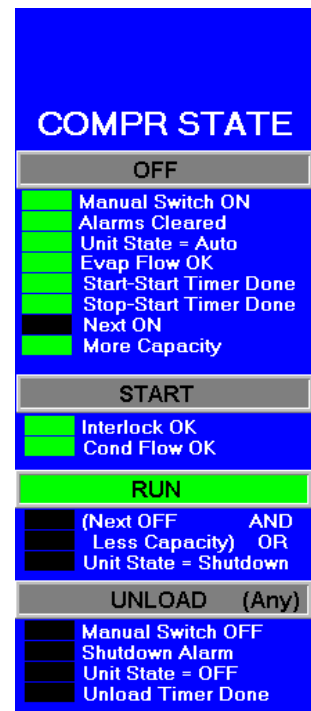

**Figure 16, View Compressor Input/Output Status**

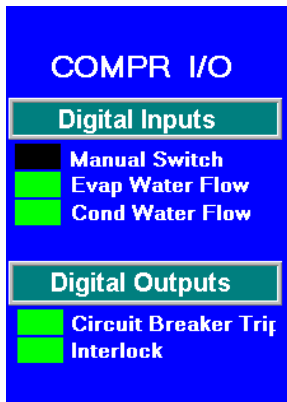

Pressing the I/O button adjacent to the compressor on the VIEW-MENU screen will access the screen shown in Figure 16. It is superimposed on the right side of the Detail View Screen. It gives the status of the *compressor* digital inputs and outputs. Many of these I/Os also appear in the Compressor State screen since they are part of the start up sequence and define the compressor state at any given time. Magnitude units will have two of any compressor screen.

A COMP button will appear in the lower left-hand corner of the Detail View Screen. This button will toggle compressor data from #1 compressor to #2 compressor.

**Figure 17, Unit Input/Output Screen**

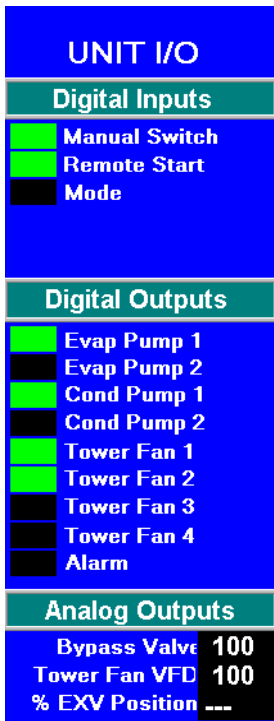

The screen shown in Figure 17 to the left gives the status of the *unit* controller digital inputs and outputs and analog outputs. The unit controller is concerned with the operation of the entire unit and its I/Os reflect this. Note that operation of condenser and evaporator water pumps and tower operation constitute most of the data flow. An illuminated block (gray in the figure) indicated that either an input or output signal exists.

Pressing the Evaporator or Condenser buttons on Detail View Screen will display pertinent vessel temperatures and pressures. The screens are very simple, self-explanatory, and not shown here.

Figure 18, Labeled Bar Graphs

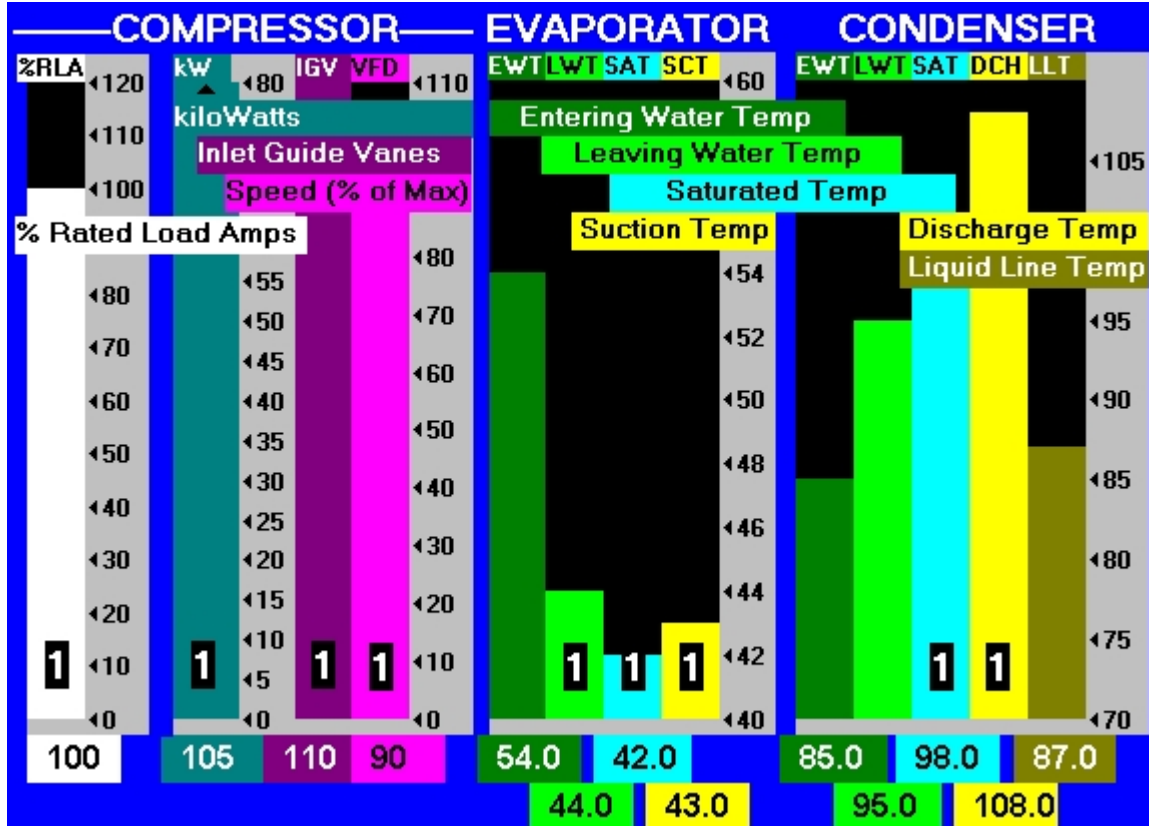

The bar chart screen is accessed from the MENU screen (Figure 14) by selecting Labeled Bar Graphs for the graphs with labels attached as shown above or select Bar Graphs for charts without labels.

Pressing “COMP” on the lower left corner of the screen will toggle between the unit’s two compressors. Pressing “MENU,” HISTORY,” “VIEW,” or “SET” buttons will forward to those respective screens.

## SET Screens

The set screens on the Interface Panel are used to input the many setpoints associated with equipment of this type. MicroTech II provides an extremely simple method for accomplishing this. (NOTE: If the Interface Panel is unavailable, the unit controller can be used to change setpoints.) Appropriate setpoints are factory set and checked by McQuay Factory Service or Factory Authorized Service Company during commissioning. However, adjustments and changes are often required to meet job conditions. Certain settings involving pumps and tower operation are field set.

Pressing the SET button found on almost every screen accesses the last SET screen used or the SERVICE screen, whichever of the two was used last.

When in any SET screen, pressing the SET button again will toggle to the SERVICE screen shown on page 52.

Figure 19, A Typical SETPOINT Screen

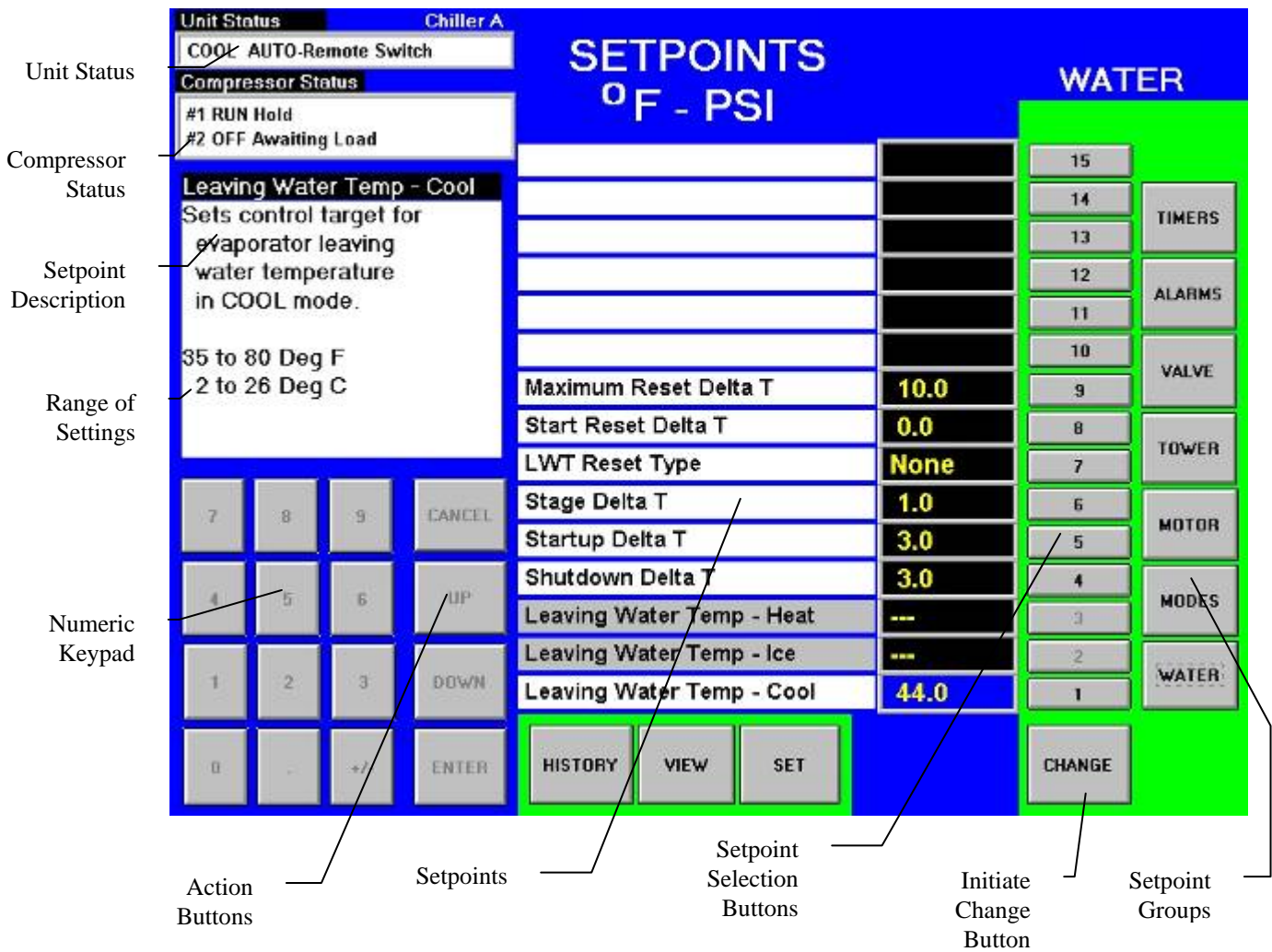

The above figure shows the Water screen with Leaving Water Temp setpoint selected. The various setpoint groups are in a column on the right side of the screen. Each button contains a number of setpoints grouped together by similar content. The WATER button (as shown) contains various setpoints relating to water temperature setpoints.

**NOTE:** Some setpoints that do not apply to a particular unit application may still be listed on the screen. They will be inactive and can be ignored.

The numbered buttons in the second from right column are pressed to select a particular setpoint. The selected setpoint will appear in blue on the screen and a description of it (with the range of available settings) will appear in the upper left-hand box.

**Procedure for Changing a Setpoint**

A list of setpoints, their default value, their available setting range, and password authority are in Table 6 on page 20 for the unit and Table 13 on page 24 for the compressor.

1. Press the applicable Setpoint Group). (A complete explanation of setpoint content of each group follows this section.)
2. Select the desired setpoint by pressing the numbered button.

3. Press the CHANGE button indicating that you wish to change a setpoint value. The KEYBOARD screen will be turned on automatically to facilitate entering the password.
  - O = Operator level password is 100
  - M = Manager level password is 2001
  - T = Technician level password
4. Press the appropriate numbers in the numeric keyboard to enter the password. There is a small delay between pressing the keypad and recording the entry. Be sure that an asterisk appears in the window before pressing the next number. Press ENTER to return to the SETPOINT screen. The password will remain open for 15 minutes after initiation and does not need to be re-entered.
5. Press CHANGE again. The right side of the screen will turn blue (inactive).
6. The numeric keypad and action buttons in the lower left-hand corner of the screen will be activated (the background will turn green). Setpoints with numeric values can be changed in two ways:
  - Select the desired value by pressing the numbered buttons. Press ENTER to enter the value or CANCEL to cancel the transaction.
  - Press the UP or DOWN button to increase or decrease the value displayed. Press ENTER to enter the value or CANCEL to cancel the transaction.

Some setpoints are text rather than numeric values. For example, LWT Reset Type can be "None" or "4-20 ma." The selection can be made by toggling between choices using the UP or Down button. If dashed lines appear in the setpoint window, it indicates that you have toggled too far and need to reverse direction. Press ENTER to enter the choice or CANCEL to cancel the transaction.

Once CHANGE is selected, the CANCEL or ENTER buttons must be pressed before another setpoint can be selected.
7. Additional setpoints can be changed by selecting another setpoint on the screen or by selecting an entirely new group of setpoints.

### **Explanation of Setpoints**

Each of the seven setpoint group of screens are detailed in the following section.

1. TIMERS, for setting timers such as start-to-start, etc.
2. ALARMS, for setting the limit and shutdown alarms.
3. VALVE, sets the parameters for operation of an optional field-installed tower bypass valve.
4. TOWER, selects the method of controlling the cooling tower and sets the parameters for fan staging/VFD.
5. MOTOR, selects motor related setpoints such as amp limits. Also has maximum and minimum rate of change of chilled water temperature.
6. MODES, selects various modes of operation such as control source, multiple compressor staging, pump staging, BAS protocol, etc.
7. WATER, leaving water temperature setpoint, start and stop delta-T, resets, etc.

## TIMERS Setpoint

Figure 20, TIMERS Setpoint Screen

The screenshot shows the 'SETPOINTS °F - PSI' screen for 'Chiller A'. On the left, there are status indicators: 'Unit Status' (COOL AUTO-Remote Switch), 'Compressor Status' (#1 RUN Hold, #2 OFF Awaiting Load), and 'Evap Recirculate Timer' (Sets the amount of time the evaporator pump must run before a compressor can start, 0.2 to 5.0 Minutes). The main area lists timer setpoints:

Timer Name	Value
Full Load Time	
Interlock Timer	180
Prelube Timer	30
Stop To Start Timer	3
Start To Start Timer	40
Evap Recirculate Timer	0.5

On the right, there is a 'TIMERS' menu with buttons numbered 1 through 15, and other function buttons like ALARMS, VALVE, TOWER, MOTOR, MODES, and WATER. At the bottom, there are buttons for HISTORY, VIEW, SET, and CHANGE.

Table 18, TIMER Setpoints

Description	No.	Default	Range	Pass-word	Comments
Full Load Timer	5	300 sec	0 to 999 sec.	M	Time compressor must load (without unloading) before vanes are considered fully open.
Interlock Timer	4	10 sec	10 to 240 seconds	M	Maximum time allowed before interlock confirmation from compressor
Stop-Start Timer	3	3 min	3 to 20 min	M	Time from when compressor stops to when it can restart
Start-Start Timer	2	40 min	15 to 60 min	M	Time from when compressor starts to when it can start again
Evap Recirculate Timer	1	30 sec	0.2 to 5 min	M	Time that evaporator pump must run before compressor start

# ALARMS Setpoint

Figure 21, ALARMS Setpoint Screen

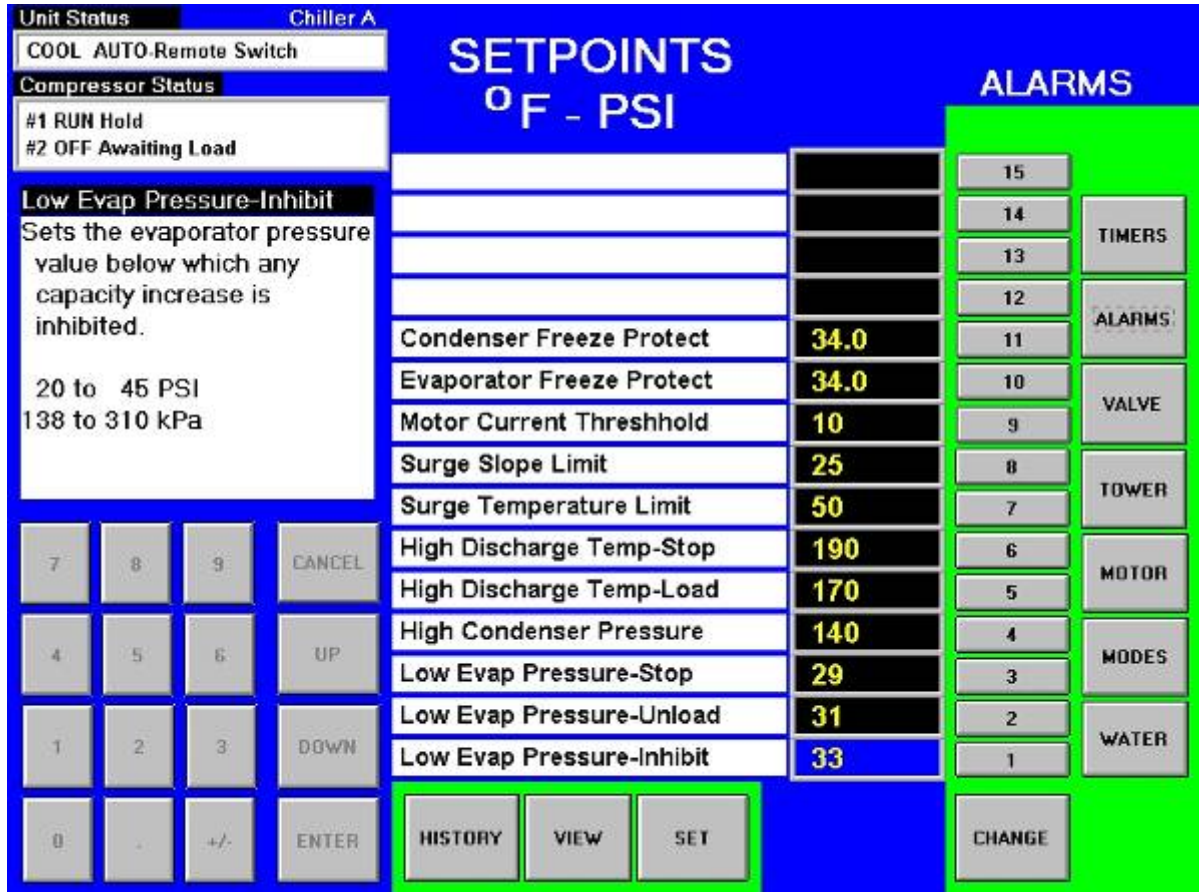

Table 19, ALARM Setpoints

Description	No.	Default	Range	Pass-word	Comments
Condenser Freeze	11	34.0 °F	-9.0 to 45.0 °F	T	Minimum cond. sat. temp. to start pump
Evaporator Freeze	10	34.0 °F	-9.0 to 45.0 °F	T	Minimum evap. sat. temp. to start pump
Motor Current Threshold	9	10%	1 to 20%	T	Min %RLA to consider that the is motor off
Surge Slope Limit	8	20 deg F/min	1 to 99 deg F/min	T	Surge temperature (ST) slope value above which alarm occurs. Active only if ST>SP7 at start
Surge Temperature Limit	7	50 °F	2 to 45 °F	T	At start, Surge Temp (ST) is compared to this SP. Alarm at ST>2x SP.
High Discharge Temp-Stop	6	190 °F	120 to 240 °F	T	Max discharge temp to shut down compressor
High Discharge Temp-Load	5	170 °F	120 to 240 °F	T	Sets discharge temp above which a forced capacity increase occurs.
High Condenser Pressure	4	140 psi	120 to 240 psi	T	Max discharge pressure, stop compressor
Low Evap Pressure, Stop	3	26 psi	10 to 45 psi	T	Min evap pressure – stop compressor
Low Evap Pressure-Unload	2	31 psi	20 to 45 psi	T	Min evap pressure – unload compressor
Low Evap Pressure-Inhibit	1	33 psi	20 to 45 psi	T	Min evap pressure – inhibit loading

## Cooling Tower Bypass VALVE Settings

Figure 22, Tower Bypass VALVE Setpoint Screen

**Unit Status**  
AUTO

**Compressor Status**  
#1 RUN  
#2 OFF

**Tower Valve Type**  
NC: Valve is normally closed to tower.  
NO: Valve is normally open to tower.

Setpoint	Value	Button	Category
Valve Control Slope Gain	25	15	TIMERS
Valve Control Error Gain	25	14	TIMERS
Valve Control Range (Max)	90	13	ALARMS
Valve Control Range (Min)	10	12	ALARMS
Temp - Max Start Position	90	11	VALVE
Maximum Start Position	100	10	VALVE
Temp - Min Start Position	60	9	TOWER
Minimum Start Position	0	8	TOWER
Stage Down @	20	7	MOTOR
Stage Up @	80	6	MOTOR
Valve Deadband (Lift)	4.0	5	MODES
Valve Deadband (Temp)	2.0	4	MODES
Valve Target (Lift)	30	3	WATER
Valve Target (Temp)	65	2	WATER
Tower Valve Type	NC to Twr	1	WATER

Navigation: 7, 8, 9, CANCEL, 4, 5, 6, UP, 1, 2, 3, DOWN, 0, ., +/-, ENTER

Actions: HISTORY, VIEW, SET, CHANGE

Table 20, Tower Bypass VALVE Setpoints (See page 46 for complete explanation.)

Description	No.	Default	Range	Pass-word	Comments
Slope Gain	15	65	10 to 99	M	Control gain for temperature (or lift) slope
Error Gain	14	55	10 to 99	M	Control gain for temperature (or lift) error
Valve Control Range(Max)	13	45%	0 to 100%	M	Maximum valve position, overrides all other settings
Valve Control Range (Min)	12	35%	0 to 100%	M	Minimum valve position, overrides all other settings
Temp - Maximum Start Position	11	85 °F	0 to 100 °F	M	Condenser EWT at which valve should be open to tower. Valve position is set to SP8
Maximum Start Position	10	80%	0 to 100%	M	Initial valve position when condenser EWT is at or above Setpoint # 9
Temp - Minimum Position	9	75 °F	0 to 100 °F	M	Condenser EWT at which initial valve position is set to Setpoint # 6
Minimum Start Position	8	10%	0 to 100%	M	Initial position of valve when condenser EWT is at or below Setpoint # 7
Stage Down @	7	20%	0 to 100%	M	Valve position below which the fans can stage down (Tower - Setpoint #2 = Valve Stage Down VFD speed below which the next fan speed can turn off (Tower - Setpoint # 2 = valve/VFD
Stage Up @	6	80%	0 to 100%	M	Valve position above which the fans can stage up (Tower - Setpoint #2 = Valve Stage Down VFD speed above which the next fan speed can turn on (Tower - Setpoint # 2 = valve/VFD
Valve Deadband (Lift)	5	4.0 psi	1.0 to 20.0 psi	M	Control deadband, Tower - Setpoint #1=Lift
Valve Deadband (Temp)	4	2.0 °F	1.0 to 10.0 °F	M	Control deadband, Tower Setpoint #1=Temp
Valve Target (Lift)	3	30 psi	10 to 130 psi	M	Target for lift pressure (Tower - Setpoint #1= Lift), Works with Setpoint # 5
Valve Setpoint (Temp)	2	65 °F	40 to 120 °F	M	Target for condenser EWT (Tower Setpoint #1= Temp), Works with Setpoint # 4
Valve Type	1	NC (To Tower)	NC, NO	M	Normally closed (NC) or normal open (NO) to tower

## Cooling TOWER Fan Settings

Figure 23, Cooling TOWER Fan Setpoint Screen (See page 46 for complete explanation.)

SETPOINTS		TOWER	
°F - PSI			
Stage #4 ON (Lift)	65	15	TIMERS
Stage #3 ON (Lift)	55	14	
Stage #2 ON (Lift)	45	13	ALARMS
Stage #1 ON (Lift)	35	12	
Stage #4 ON (Temp)	85	11	VALVE
Stage #3 ON (Temp)	80	10	
Stage #2 ON (Temp)	75	9	TOWER
Stage #1 ON (Temp)	70	8	
Stage Differential (Lift)	6.0	7	MOTOR
Stage Differential (Temp)	3.0	6	
Fan Stage Down Time	5	5	MODES
Fan Stage Up Time	2	4	
Cooling Tower Stages	4	3	WATER
Twr Bypass Valve/Fan VFD	Valve SP	2	
Cooling Tower Control	Temp	1	

Table 21, Tower Fan Settings

Description	No.	Default	Range	Pass-word	Comments
Stage #4 On (Lift)	15	35 psi	10 to 130 psi	M	Lift pressure for fan stage #1 on
Stage #3 On (Lift)	14	45 psi	10 to 130 psi	M	Lift pressure for fan stage #2 on
Stage #2 On (Lift)	13	55 psi	10 to 130 psi	M	Lift pressure for fan stage #3 on
Stage #1 On (Lift)	12	65 psi	10 to 130 psi	M	Lift pressure for fan stage #4 on
Stage #4 On (Temp)	11	70 °F	40 to 120 °F	M	Temperature for fan stage #1 on
Stage #3 On (Temp)	10	75 °F	40 to 120 °F	M	Temperature for fan stage #2 on
Stage #2 On (Temp)	9	80 °F	40 to 120 °F	M	Temperature for fan stage #3 on
Stage #1 On (Temp)	8	85 °F	40 to 120 °F	M	Temperature for fan stage #4 on
Stage Differential (Lift)	7	6.0 psi	1.0 to 20.0 psi	M	Fan staging deadband with Setpoint # 1=Lift
Stage Differential (Temp)	6	3.0 °F	1.0 to 10.0 °F	M	Fan staging deadband with Setpoint #1=Temp
Stage Down Time	5	5 min	1 to 60 min	M	Time delay between stage up/down event and next stage down
Stage Up Time	4	2 min	1 to 60 min	M	Time delay between stage up/down event and next stage up
Tower Stages	3	2	1 to 4	M	Number of fan stages used
Valve/VFD Control	2	None	None, Valve Setpoint, Valve Stage, VFD Stage, Valve SP/VFD Stage	M	None: No tower valve or VFD Valve Setpoint: Valve controls to VALVE SP3(4) & 5(6) Valve Stage: Valve control setpoint changes to fan stage setpoint VFD Stage: 1 <sup>st</sup> fan is VFD controlled, no valve Valve Setpoint/VFD Stage: Both valve and VFD
Tower Control	1	None	None, Temperature, Lift	M	None: No tower fan control Temperature: Fan and valve controlled by EWT Lift: Fan and valve controlled by lift pressure

## Explanation of Tower Control Settings

The MicroTech II controller can control cooling tower fan stages, a tower bypass valve, and/or a tower fan VFD if the chiller has a dedicated cooling tower.

The Tower Bypass Valve position will always control the Tower Fan Staging if Valve Setpoint or Stage Setpoint is selected.

There are five possible tower control strategies as noted below and explained in detail later in this section. They are selected from SETPOINT TOWER SP2.

1. NONE, Tower fan staging only, which is not recommended. In this mode the tower fan staging (up to 4 stages) is controlled by either the condenser Entering Water Temperature (EWT) or LIFT pressure (difference between the condenser and evaporator pressure). Tower bypass or fan speed are not controlled.
2. VALVE SP, Tower staging with low-limit controlled bypass valve. In this mode the tower fans are controlled as in #1, plus a tower bypass valve is controlled to provide a minimum condenser EWT. There is no interconnection between the fan control and the valve control.
3. VALVE STAGE, Tower staging with stage controlled bypass valve. In this mode the bypass valve controls between fan stages to smooth the control and reduce fan cycling.
4. VFD STAGE. In this mode a VFD controls the first fan. Up to 3 more fans are staged on and off and there is no bypass valve.
5. VALVE/VFD, Tower fan control with VFD plus bypass valve control.

### 1. Tower Fan Staging Only (NONE); This is not a recommended control strategy.

The following settings are used for the Tower Fan Staging Only mode, (SP= setpoint)

#### a) TOWER SETPOINT Screen

- i) SP1. Select TEMP if control is based on condenser EWT or LIFT if based on compressor lift expressed in degrees.
- ii) SP2. Select NONE for no bypass valve or fan VFD control.
- iii) SP3. Select one to four fan outputs depending on the number of fan stages to be used. More than one fan can be used per stage through the use of relays.
- iv) SP4. Select STAGE UP TIME from 1 to 60 minutes. The default value of 2 minutes is probably a good starting point. The value may need to be adjusted later depending on actual system operation.
- v) SP5. Select STAGE DOWN TIME from 1 to 60 minutes. The default value of 5 minutes is probably a good starting point. The value may need to be adjusted later depending on actual system operation.
- vi) If TEMP is selected in SP1, use
  - (1) SP6. Select STAGE DIFFERENTIAL in degrees F, start with default of 3 degrees F.
  - (2) SP8-11. Set the STAGE ON temperatures consistent with the temperature range over which the condenser EWT is desired to operate. The default values of 70°F, 75°F, 80°F and 85°F are a good place to start in climates with moderate wet bulb temperatures. The number of STAGE ON setpoints used must be the same as SP3.

#### b) If LIFT is selected in SP1, use

- i) SP7. Select STAGE DIFFERENTIAL in PSI. Start with default of 6 PSI.
- ii) SP12-15. Start with default setpoints. The number of STAGE ON setpoints used must be the same as SP3.

See Figure 10 on page 8 for fan staging field wiring connection points.

## 2. Tower Fan Staging With Bypass Valve Controlling Minimum EWT (VALVE SP).

### 1) TOWER SETPOINT Screen

- a) SP1. Select TEMP if control is based on condenser EWT or LIFT if based on compressor lift expressed in pressure.
- b) SP2. Select Valve SP for control of bypass valve based on temperature or lift.
- c) SP3. Select one to four fan outputs depending on the number of fan stages to be used. More than one fan can be used per stage through the use of relays.
- d) SP4. Select STAGE UP TIME from 1 to 60 minutes. The default value of 2 minutes is probably a good starting point. The value may need to be adjusted later depending on actual system operation.
- e) SP5. Select STAGE DOWN TIME from 1 to 60 minutes. The default value of 5 minutes is probably a good starting point. The value may need to be adjusted later depending on actual system operation.
- f) If TEMP is selected in SP1, use
  - i) SP6. Select STAGE DIFFERENTIAL in degrees F, start with default of 3 degrees F.
  - ii) SP8-11. Set the STAGE ON temperatures consistent with the temperature range over which the condenser EWT is desired to operate. The default values of 70°F, 75°F, 80°F and 85°F are a good place to start in climates with moderate wet bulb temperatures. The number of STAGE ON setpoints used must be the same as SP3.
- g) If LIFT is selected in SP1, use
  - i) SP7. Select STAGE DIFFERENTIAL in PSI. Start with default of 6 PSI.
  - ii) SP12-15. Start with default setpoints. The number of STAGE ON setpoints used must be the same as SP3.

### 2) VALVE SETPOINT Screen

- a) SP1, Select NC or NO depending if valve is closed to tower with no control power or open to tower with no control power.
- b) If TEMP was selected for fan control above, use
  - i) SP2, Set the VALVE TARGET (setpoint), usually 5 degrees below the minimum fan stage setpoint established in TOWER SP11. This keeps full flow through the tower until the last fan is staged off.
  - ii) SP4, Set VALVE DEADBAND, the default of 2 degrees F is a good place to start.
  - iii) SP8, Set MINIMUM VALVE POSITION when EWT is at or below SP9. Default is 0%.
  - iv) SP9, Set the EWT at which the valve position will be at (SP8). Default is 60°F.
  - v) SP10, Set the initial valve position when EWT is at or above SP11. Default is 100%.
  - vi) SP11, Set the EWT at which initial valve position is set to SP10. Default is 90°F.
  - vii) SP12, Set the minimum position to which the valve can go. Default is 10%.
  - viii) SP13, Set the maximum position to which the valve can go. Default is 100%.
  - ix) SP14, Set the control gain for error. Default is 25.
  - x) SP15, Set the control gain for slope. Default is 25.

### CAUTION

Setpoints 14 and 15 are site specific, dealing with system fluid mass, component size and other factors affecting the reaction of the system to control inputs. These setpoints should be set by personnel experienced with setting up this type of control to avoid possible equipment damage.

c) If LIFT was selected for fan control, use:

- i) SP3, Set the VALVE TARGET (setpoint), usually 30 psi below the minimum fan stage setpoint established in TOWER SP15. This keeps full flow through the tower until the last fan is staged off.
- ii) SP5, Set VALVE DEADBAND, the default of 6 psi is a recommended initial setting.
- iii) SP12, Set the minimum position to which the valve can go. Default is 10%.
- iv) SP13, Set the maximum position to which the valve can go. Default is 100%.
- v) SP14, Set the control gain for error. Default is 25.
- vi) SP15, Set the control gain for slope. Default is 25.

NOTE: Setpoints 14 and 15 are site specific dealing with system fluid mass, component size and other factors affecting the reaction of the system to control inputs. These setpoints should be set by personnel experienced with setting up this type of control.

**Figure 24, Bypass Valve Positions**

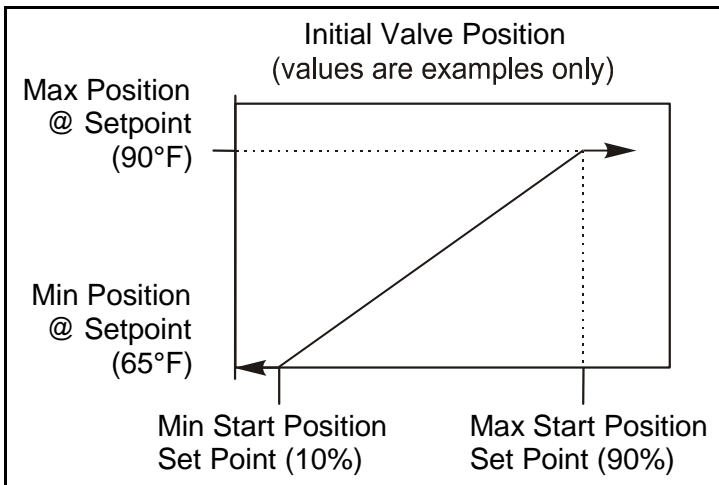

See Figure 10 on page 8 for fan staging and bypass valve field wiring connection points.

### 3. Tower staging with bypass valve controlled by fan stage (VALVE STAGE)

This mode is similar to #2 above except that the bypass valve setpoint changes to be set at the same point of whatever fan stage is active rather than just maintaining a single minimum condenser EWT. In this mode the valve controls between fan stages and tries to maintain the fan stage setting in effect. When it is max open or max closed (staging up or down) and the temperature (or lift) moves to the next fan stage, the valve will go the opposite max setting. This mode reduces fan cycling.

This mode is programmed the same as Mode #2 above except that in SETPOINT, TOWER, SP2, VALVE STAGE is selected instead of VALVE SP and:

- SP6, Set the valve position (% open) above which the first fan can stage on (fan stage ON temperature and STAGE UP TIMER must also be satisfied). Default is 80%.
- SP7, Set the valve position (% closed) below which the first fan can stage off (the fan stage temperature and STAGE DOWN TIMER must also be satisfied). Default is 20%.

**4. Fan VFD, no bypass valve (VFD STAGE)** The fan VFD mode assumes the tower is driven by one large fan. Set up is as above except in SETPOINT, TOWER, SP2, VALVE/VFD is selected.

# MOTOR Setpoint Screen

Figure 25, MOTOR Setpoint Screen

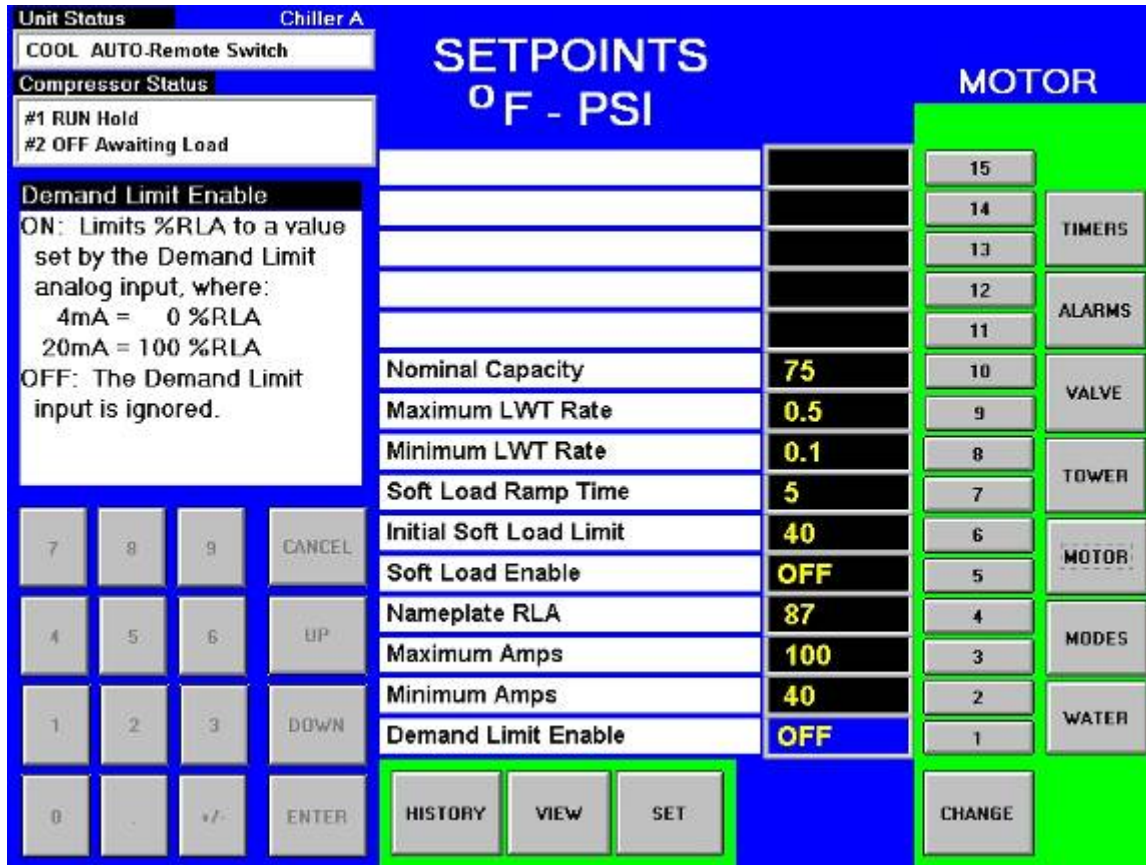
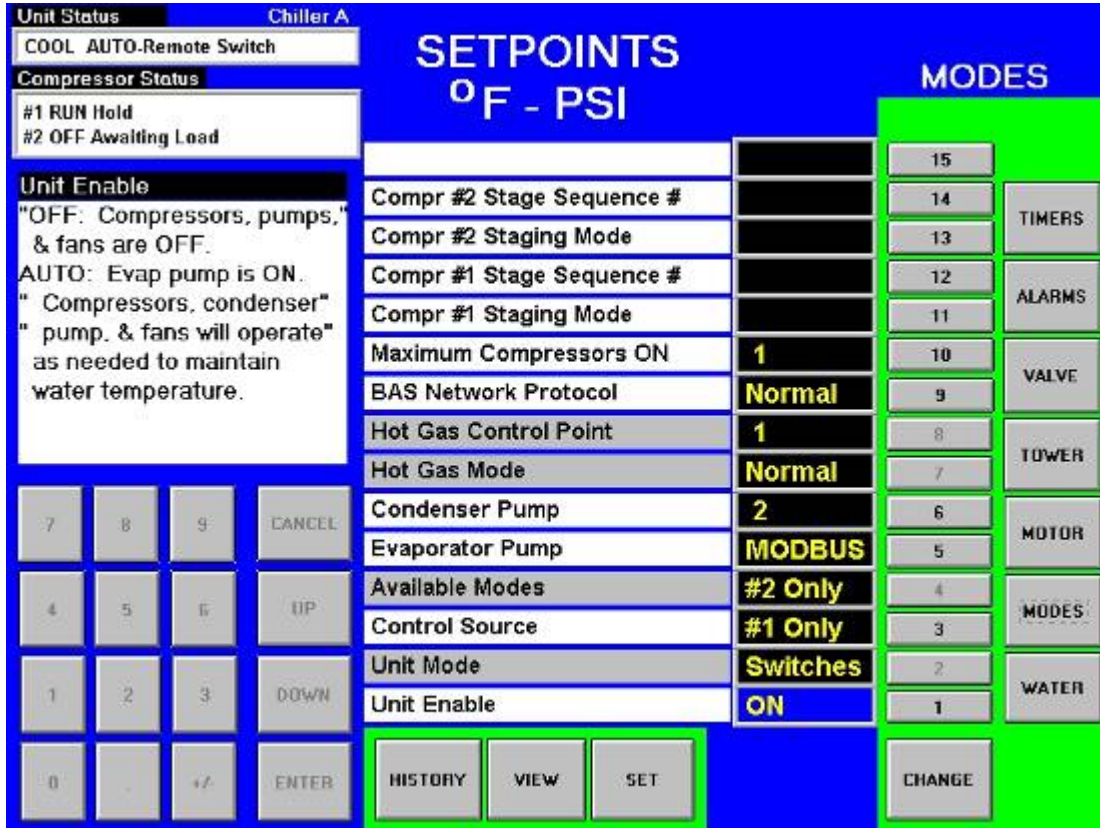

Table 22, MOTOR Setpoint Settings

Description	No.	Default	Range	Pass-word	Comments
Nominal Capacity	10	100	0 to 9999 Tons		Determines when to shut off a compressor
Maximum LWT Rate	9	0.5 °F/min	0.1 to 5.0 °F/min	M	Inhibits loading if LWT change exceeds the setpoint value.
Minimum LWT Rate	8	0.1 °F/min	0.1 to 5.0 °F/min	M	Additional compressor can start if LWT change is below setpoint.
Soft Load Ramp Time	7	5 min	1 to 60 min	M	Time period to go from initial load point (% RLA) set in SP 5 to 100% RLA
Initial Soft Load Amp Limit	6	40%	10 to 100%	M	Initial amps as % of RLA uses SP4 & 6
Soft Load Enable	5	OFF	OFF, ON	M	Soft load on or off Uses SP6 & 7
Nameplate RLA	4		52 to 113 Amps	T	RLA value from compressor nameplate
Maximum Amps	3	100%	10 to 100%	T	% RLA above which loading is inhibited (Load Limit) SP + 5% unloads compressor
Minimum Amps	2	40%	5 to 80%	T	% RLA below which unloading is inhibited
Demand Limit Enable	1	OFF	OFF, ON	O	ON sets %RLA at 0% for 4 mA external signal and at 100% RLA for 20 mA signal OFF – signal is ignored

# MODES Setpoints

Figure 26, MODES Setpoint Screen



NOTE: Gray setpoints are not used with Magnitude chillers.

Table 23, MODES Setpoint Settings

Description	No.	Default	Range	Pass-word	Comments
Comp # 2 Stage Sequence	10	1	1,2, ... (# of Compressors)	M	Sets sequence number for # 2 compressor, if 1 it is always first to start, if 2 is always second (Note 1)
Comp # 2 Stage Mode	9	Normal	Normal, Efficiency, Pump, Standby	M	Normal uses standard sequencing Efficiency starts one compressor on each unit Pump starts all compressors on one chiller first Standby uses this compressor only if another fails.
Comp #1 Stage Sequence	8	1	1,2, ... (# of Compressors)	M	Sets sequence number for # 1 compressor, if 1 it is always first to start, if 2 is always second (Note 1)
Comp #1 Stage Mode	7	Normal	Normal, Efficiency, Pump, Standby	M	Ditto No. 9.
Max. Comp. ON	6	1	1-16	M	Total number of compressors minus standby
BAS Protocol	5	MODBUS	None, Local, BACnet, LonWorks, MODBUS, Remote	M	Sets BAS Standard Protocol to be used, or LOCAL if none.
Cond Pump	4	Pump #1 Only	Pump #1 Only, Pump #2 Only, Auto Lead, #1 Primary, #2 Primary	M	Pump #1 Only, Pump #2 Only, use only these pumps AUTO, balance hours between #1 and #2 #1 Primary, #2 Primary, if primary fails, use other
Evap Pump	3	Pump #1 Only	Pump #1 Only, Pump #2 Only, Auto Lead, #1 Primary, #2 Primary	M	Pump #1 Only, Pump #2 Only, use only these pumps AUTO, balance hours between #1 and #2 #1 Primary, #2 Primary, if primary fails, use other
Control Source	2	LOCAL	LOCAL, BAS, SWITCH	O	Sets control source
Unit Enable	1	OFF	OFF, AUTO	O	OFF, everything is off. AUTO, Evap pump on, comp, cond pump and tower on as required to meet LWT

1. If both compressors have the same sequence number, they will automatically balance starts and run-hours.
2. See page 68 for further details on pump operation.

## WATER Setpoints

Figure 27, WATER Setpoint Screen

**Unit Status** Chiller A  
COOL AUTO-Remote Switch

**Compressor Status**  
#1 RUN Hold  
#2 OFF Awaiting Load

**Leaving Water Temp - Cool**  
Sets control target for evaporator leaving water temperature in COOL mode.  
35 to 80 Deg F  
2 to 26 Deg C

**SETPOINTS °F - PSI**

Maximum Reset Delta T	10.0
Start Reset Delta T	0.0
LWT Reset Type	None
Stage Delta T	1.0
Startup Delta T	3.0
Shutdown Delta T	3.0
Leaving Water Temp - Heat	---
Leaving Water Temp - Ice	---
Leaving Water Temp - Cool	44.0

**WATER**

15  
14  
13  
12  
11  
10  
9  
8  
7  
6  
5  
4  
3  
2  
1

TIMERS  
ALARMS  
VALVE  
TOWER  
MOTOR  
MODES  
WATER

CANCEL  
UP  
DOWN  
ENTER  
HISTORY  
VIEW  
SET  
CHANGE

Table 24, WATER Setpoint Settings

Description	N0.	Default	Range	Pass-word	Comments
Max Reset Delta-T	7	0.0°F	0.0 to 20.0 °F	M	Set the maximum reset that can occur, in degrees F if LWT reset is selected or max reset at 20 mA input if 4-20 mA is selected in SP7
Start Reset Delta-T	6	10. 0°F	0.0 to 20.0 °F	M	Sets the evap delta-T above which Return reset begins.
LWT Reset Type	5	NONE	NONE, RETURN, 4-20mA	M	Select reset type, NONE for none, RETURN for resetting chilled water based on the entering water, or 4-20 mA for external analog signal
Stage Delta-T	4	1.0	0.5 to 5°F	M	Sets the temperature the leaving water must be above setpoint for next compressor to start.
Startup Delta-T	3	3.0°F	0.0 to 10.0 °F	M	Degrees above setpoint for compressor to start.
Shutdown Delta-T	2	3.0°F	0.0 to 3.0 °F	M	Degrees below setpoint for compressor to stop.
Cool LWT	1	44. 0°F	40.0 to 80.0 °F	M	Evaporator LWT setpoint in COOL mode

# SERVICE Screen

Figure 28, Service Screen

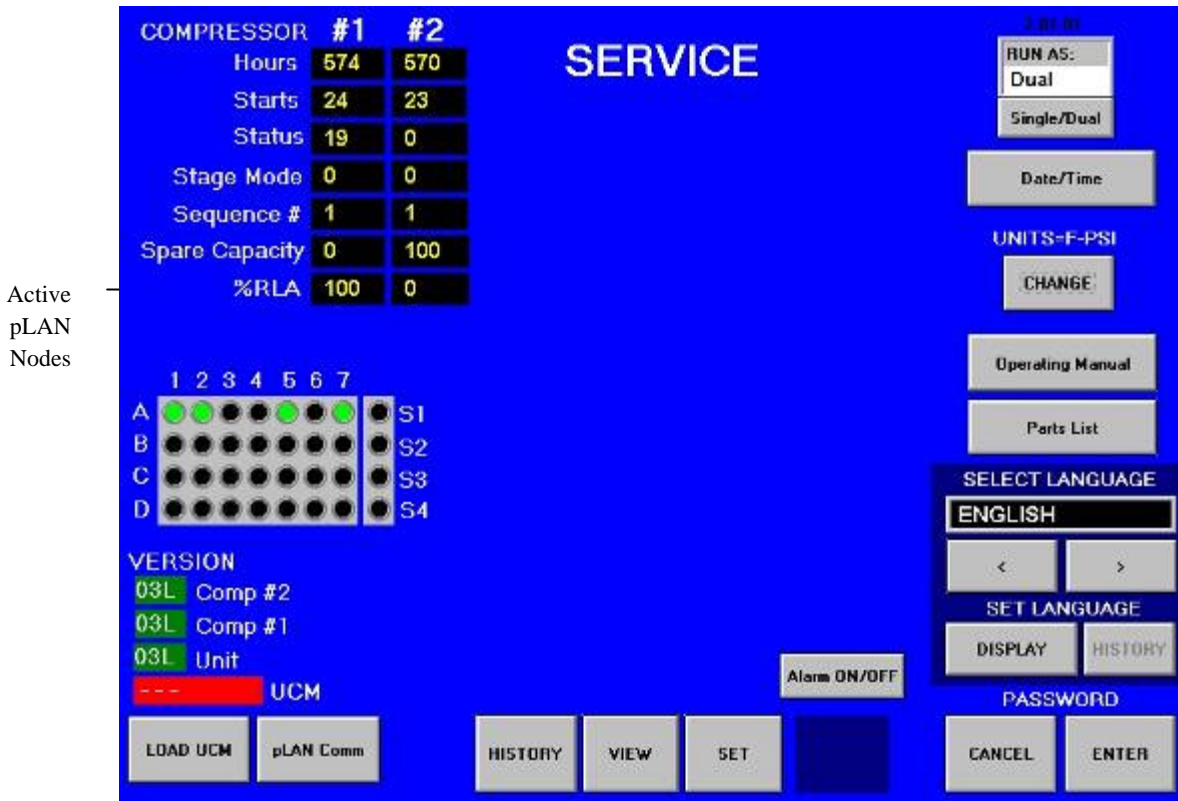

The SERVICE screen is accessed by pressing SET from any SET screen. In other words, it is the second "SET" screen. While containing information and activity buttons for the service technician, it also has valuable information for the operator.

The upper left corner contains compressor information such as number of starts and operating hours for each compressor. "Spare Capacity" is used to set the compressor stopping increments.

The Active pLAN Nodes matrix shows active control components on the pLAN. A, B, C, D are individual chillers. 1 and 2 are compressor controllers, 5 is the unit controller and 7 is the interface panel. pLAN Comm is used for setting up multiple chillers and is set at startup by the McQuay startup technician as is LOAD UCM.

CHANGE UNITS button allows selection of Inch-Pounds or Metric units of measure on the OITS.

SELECT LANGUAGE allows toggling between the available languages. The language can be set separately for display or history, which is used for alarm and trend files.

The version numbers shown in the lower left corner are the controllers' software identification. The number in the upper right corner is the Operator Interface Panel software identification number. These numbers may be required by McQuay to answer questions about unit operation or to assist in possible future upgrades of software.

The PASSWORD button is used to access the Keyboard screen to enter a password.

The Alarm ON/OFF button is usually only found on demonstration software.

The red ALARM light appears on this, and many other screens, when an alarm becomes active. There is no alarm active on this demonstration screen, so the Alarm shows as dark blue.

OPERATING MANUAL displays the manual in Adobe. It can be downloaded via the USB port.

PARTS LIST displays the list. It may not be active on some units.

# HISTORY Screens

Figure 29, History Trend Graph

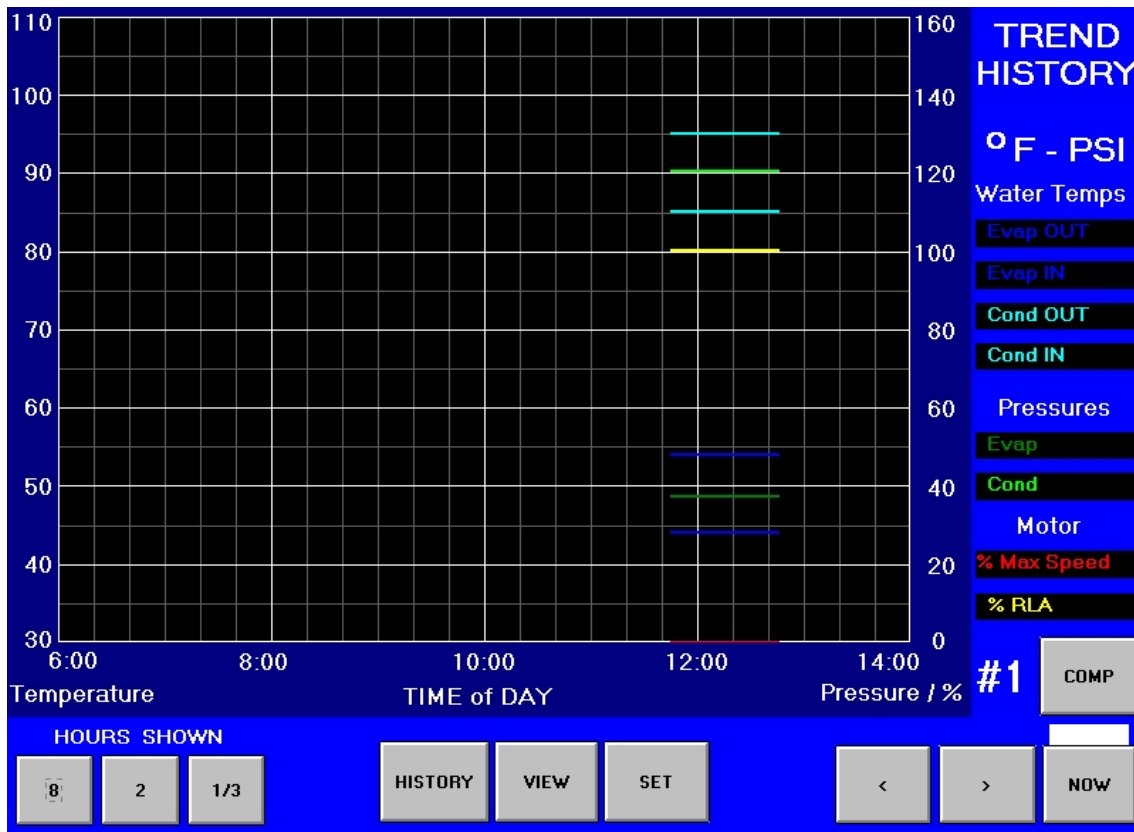

The Trend History Overview allows the user to view the various parameters listed on the right side of the screen. The temperature scale in °F is on the left. Pressure in psi and % RLA are represented by the right-hand scale. The screen can display history for 8-hour, 2-hour or 20-minute periods by pressing 8, 2, or 1/3 respectively.

Pressing NOW for any time period will start the display for the current time beginning on the right of the screen with history flowing to the left.

The arrow buttons scroll the time period forward or backward. Obviously if NOW is selected, the forward button > will not go into the future.

The COMP button toggles between compressors one and two.

Figure 30, Alarm History/Floppy Download

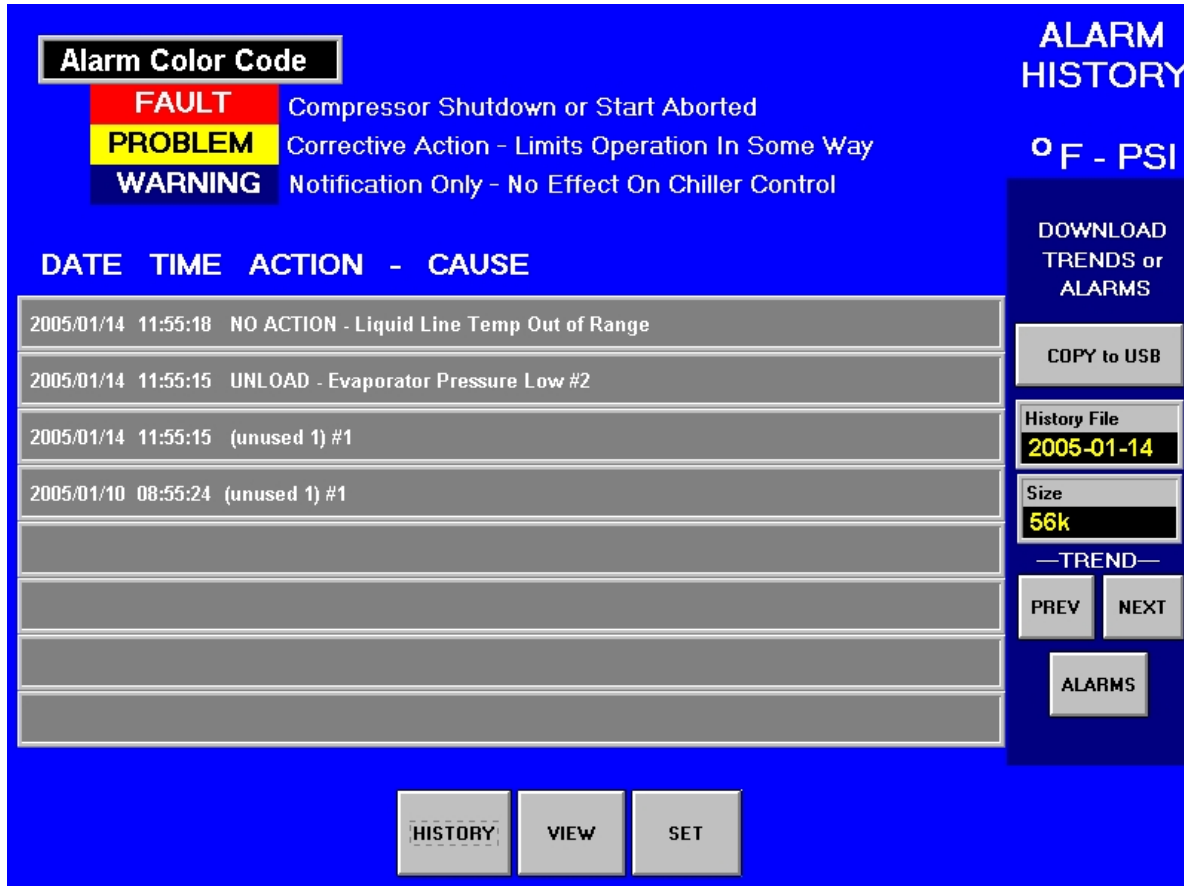

The Alarm History lists the alarms with the most current on top with date stamp, action taken and the cause of the alarm. It is accessed from the history screen by pressing HISTORY again.

The alarms have a color code as follows:

- Faults (shutdowns) = Red
- Problems (limit alarms) = Yellow
- Warnings (notifications) = Dark Blue

## Download Data

This screen is also used to download the Trend History (Figure 29) selected by date *or* the Alarm History shown above. Download is via a USB port located in the control panel.

- For Alarms, press the ALARMS button on the screen, then press the COPY to USB button.
- For Trend History, select the desired History File by date using the PREV or NEXT buttons, then press the COPY to USB button.

# ACTIVE ALARM Screen

Figure 31, Active Alarms

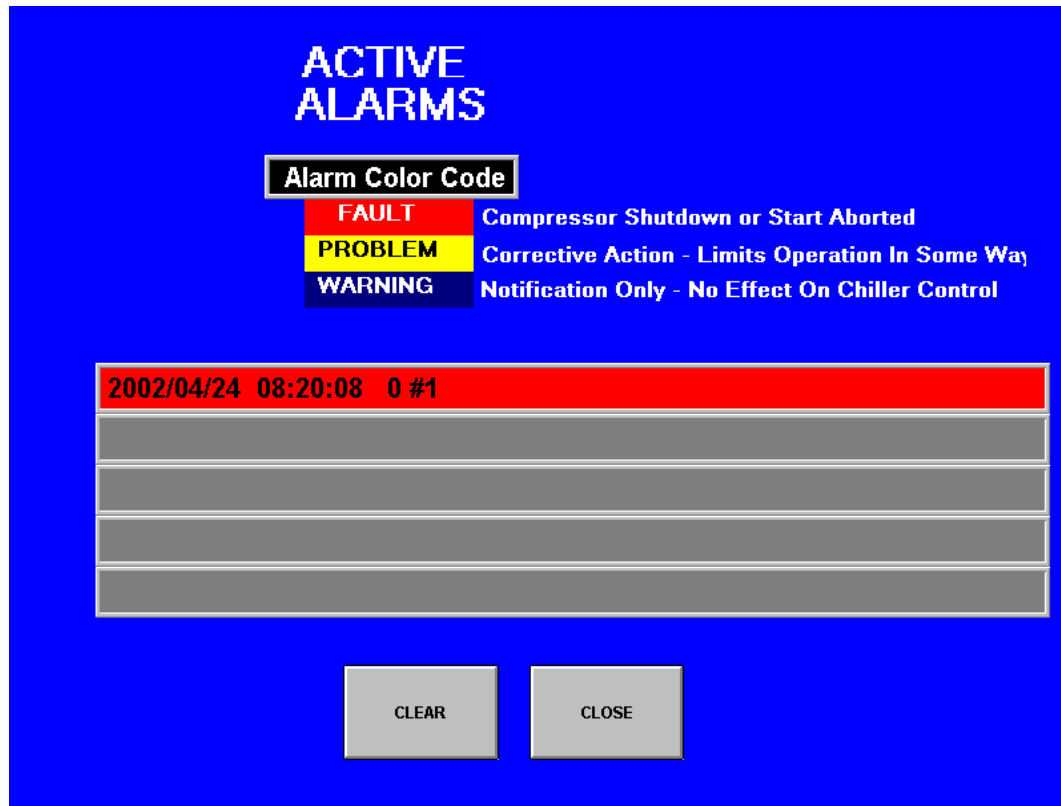

The Active Alarm screen is only accessible when an active alarm exists on the unit. Pressing the red alarm signal on any screen will access this screen. It can also be accessed from the SERVICE screen by pressing the dark blue button (where the Alarm indicator normally appears). There are no alarms active on this demonstration screen.

Alarms are arranged in order of occurrence, with the most recent on top.. Once the abnormal condition is corrected, pressing the "CLEAR" key will clear the alarm.

The current active alarms (there may be more than one) are displayed. Note that the alarms are color-coded red for FAULT (equipment protection control) that causes a rapid compressor shutdown, yellow for PROBLEM (limit alarm) that will inhibit loading, or load or unload the compressor, and blue for WARNING which is information only and takes no action. Faults, Problems, and Warnings as detailed on pages 21 and 25.

The date/time and cause of the alarm are displayed.

After eliminating the cause of the alarm, clear the alarm by pressing the CLEAR button. This will clear the alarm from the register and allow the unit to restart after going through the start sequence. The alarm notice will be deleted from the screen.

However, if the cause of the alarm is not remedied, the alarm is still active and the alarm message will remain open. The unit will not begin its starting sequence.

Figure 32, Keyboard

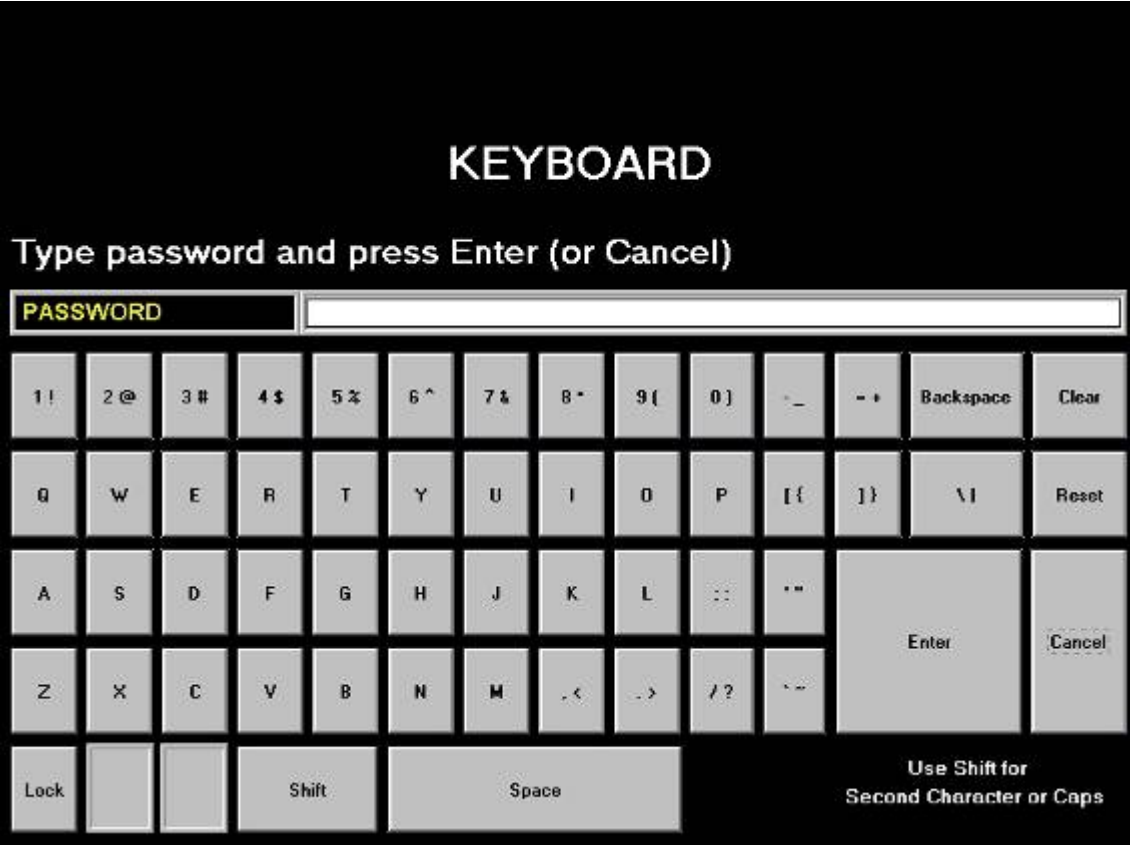

The keyboard is only used to enter the password when attempting to enter or change a setpoint. Input the number (100 for operator, 2001 for manager level) and press Enter to enter the password. The screen will automatically revert back to the previous Set screen.

This screen will appear automatically when a password is required for changing a setpoint. It can also be access from the service screen (second set screen) by pressing PASSWORD.

# Unit Controller Menu Screens

---

The unit controller, located in the control panel adjacent to the OITS, is the only controller used by the unit operator. In addition to unit functions, most compressor parameters are viewable on it, and all setpoints can be accessed from it.

## Unit of Measure

SI units of measure can be selected with the appropriate setpoint screen but will appear only on the OITS. The controller LCD screens read only in inch-pounds unit of measure.

## Menu Structure (Hierarchical)

A hierarchical menu structure is used to access the various screens. Each menu screen can have one to four lines of information. Optionally, the last menu selection can access one of a set of screens that can be navigated with the UP/DOWN arrow keys (see the scrolled menu structure below). Menu selection is initiated by pressing the MENU key, which changes the display from a data screen to a menu screen. Menu selections are then made using the arrow keys according to labels on the right side of the display (the arrows are ignored). When the last menu item is selected, the display changes to the selected data screen. An example follows showing the selection of the “VIEW COMPRESSOR” (n) screen.

Suppose the current screen is:

```
ALARM LOG
  (data)
  (data)
  (data)
```

After pressing the MENU button, the top-level menu screen will show:

```
< ALARM
< VIEW
< SET
<
```

After pressing the “VIEW” menu button, a menu screen will show:

```
VIEW < COMPRESSOR
      < UNIT
      < EVAPORATOR
      < CONDENSER
```

After pressing the “COMPRESSOR” menu button, the selected data screen will show:

```
VIEW COMP (n)
  (screen n data)
  (screen n data)
  (screen n data)
```

Where “n” is the number of the last viewed COMPRESSOR screen. The arrow keys will automatically return to the “scroll” mode at this time. Different compressor screens can then be selected with the UP/DOWN arrow keys.

The complete menu structure follows. Data screens are shown as [data] when a single screen is at the bottom of the menu structure and as [data n] when multiple screens are available (using UP/DOWN keys).

## Menu Structure (Scrolled)

As an alternate to selecting screens with the menu function, it is possible to scroll through all of them with the 4 arrow keys. For this use, the screens are arranged logically in a matrix as shown in Figure 33.

## Menu Matrix

**Figure 33, Unit Controller Menu Matrix**

View Unit Information				View Compressor Information		View Evaporator
VIEW UNIT STATUS(1) UNIT= OFF COMP#1 OFF #2RUN Ev/Cn Pmps=OFF/OFF	VIEW UNIT WATER(1)°F In Out Delta Evap 00.0 00.0 00.0 Cond 00.0 00.0 00.0	VIEW UNIT REFRG (1) psi °F Sat Evap 000.0 000.0 Sat Cond 000.0 000.0	VIEW UNIT TOWER (1) Stages ON= 0 of 2  Setpoint= XXX °F	VIEW COMP 31 (1) State = OFF % RLA = 000% Evap LWT = 054.0°F	VIEW COMP#2 (1) State = RUN % RLA = 095% Evap LWT = 054.0°F	VIEW EVAPORATOR Suct SH = 000.0°F Approach = 00.0°F  See NOTE 1
VIEW UNIT STATUS(2) Comp#1 OFF Start-Start Tmr Clr Inhibits None	VIEW UNIT WATER (2) IN OUT DELTA HtRc NA NA NA Cond NA	VIEW UNIT REFRG (2) Suct Line = 000.0°F Liquid Line = 000.0°F Lift Press = 000.0psi	VIEW UNIT TOWER (2) Bypass Valve= XXX% VFD Speed = XXX%	VIEW COMP (2) psi Cond Press = 000.0 Evap Press = 000.0 Lift Press = 000.0	VIEW COMP#2 (2) psi Cond Press = 000.0 Evap Press = 000.0 Lift Press = 000.0	
VIEW UNIT STATUS(3) Comp#2 RUN Start-Start Tmr Clr Inhibits None	VIEW UNIT WATER (3) Water Flow Rates Evap = XXXXX GPM Cond = XXXXX GPM			VIEW COMP (3) psi WMC Compressor Oilless Design (blank mask page)	VIEW COMP#2 (3) psi WMC Compressor Oilless Design (blank mask page)	
				VIEW COMP (4) °F Cavity Temp=000.0°F Invert Temp=000.0°C Lift Temp = 00.0°F	VIEW COMP#2 (4) °F Cavity Temp=000.0°F Invert Temp=000.0°C Lift Temp = 00.0°F	
				VIEW COMP (5) °F Temp SH Suction 000.0 00.0 Discharge 000.0 00.0	VIEW COMP#2 (5) °F Temp SH Suction 000.0 00.0 Discharge 000.0 00.0	
				VIEW COMP (6) psi °F SatEvap 000.0 000.0 SatCond 000.0 000.0	VIEW COMP#2 (6) psi °F SatEvap 000.0 000.0 SatCond 000.0 000.0	
				VIEW COMP (7) Hours = 00000 x10 Starts = 00000	VIEW COMP#2 (7) Hours = 00000 x10 Starts = 00000	

**The right half of the matrix is continued on next page**

**NOTE:** There is a VIEW CONDENSER menu to the right of VIEW EVAPORATOR, but omitted from this matrix due to space limitations.

**Table Continued**

VIEW ALARMS	SET SETPOINTS				PASSWORD	
Alarm Log: 01 description HH:MM:SS MM/DD/YY	SET UNIT SPs (1) Unit Enable = OFF Unit Mode = COOL Source = SWITCHES	SET COMP#1 SPs (1) Demand Limit=OFF Minimum Amps=040% Maximum Amps=100%	SET COMP#2 SPs (1) Demand Limit=OFF Minimum Amps=040% Maximum Amps=100%	SET ALARM LMTs (1) LowEvPrHold=33psi LowEvPrUnld=31psi LowEvPrStop=29psi	SET TOWER SPs (1) TowerControl=(type?) Tower Stages=4 StageUP/Dn=080/020	SET PASSWORD Enter Password:00000 No Access Given
Alarm Log: 02 description HH:MM:SS MM/DD/YY	SET UNIT SPs (2) Available Modes = COOL Select w/Unit Off	SET COMP SPs (2) StageMode =Normal StageSequence# = 01 Max Compr ON = 01	SET COMP#2 SPs (2) StageMode =Normal StageSequence# = 01 Max Compr ON = 01	SET ALARM LMTs (2) HighCondPr =140psi HiDschT-Load=170°F HiDschT-Stop=190°F	SET TOWER SPs (2) Stage ON #1 #2 #3 #4 xxx xxx xxx xxx	SET PASSWORD (2) Tech Password 00000 00000 No Access Given
Alarm Log: 03 to 25 description HH:MM:SS MM/DD/YY	SET UNIT SPs (3) Cool LWT = 44.0°F	SET COMP SPs (3) StageDeltaT = 1.0°F Stop-Start = 03 min Start-Start = 40 min	SET COMP#2 SPs (3) StageDeltaT = 1.0°F Stop-Start = 03 min Start-Start = 40 min	SET ALARM LMTs (3) WMC Compressor Oilless Design (blank mask page)	SET TOWER SPs (3) StageDiff= (type?) StageUp = 02 min StageDown=05 min	
^	SET UNIT SPs (4) Leaving Water Temp StartDelta = 3.0°F StopDelta = 3.0°F	SET COMP SPs (4) Full Load = 300 sec Name Plate RLA 085	SET COMP#2 SPs (4) Full Load = 300 sec	SET ALARM LMTs (4) Surge Slp Str=20°F Surge Tmp Run=06°F MtrCurThrsld=10%	SET TOWER SPs (4) Valve/VFD Control= None Valve Type=NC	
^	SET UNIT SPs (5) Rest Type = NONE MaxResetDT =00.0°F StrtResetDT = 10.0°F	SET COMP SPs (5) Nom Capacity = 0100T	SET COMP#2 SPs (5) Nom Capacity = 0100T	SET ALARM LMTs (5) Evap Freeze= 34.0°F Cond Freeze= 34.0°F	SET TOWER SPs (5) Valve Sp= (type?) Valve DB= (type?)	
^ ▼	SET UNIT SPs (6) Soft Load = OFF BeginAmpLimit= 040% SoftLoadRamp=05min	SET COMP SPs (6) InterLokTmr= 010sec UnloadTimer = 030 sec	SET COMP#2 SPs (6) UnloadTimer = 060 sec PostlubeTmr = 030 sec		SET TOWER SPs (6) ValveStartPosition Min=010% @ 060°F Max=090% @ 090°F	
Alarm Log: 25 description HH:MM:SS MM/DD/YY	SET UNIT SPs (7) Max/Min LWT Rates Max = 0.5°F/min Min = 0.1°F/min	SET COMP SPs (7) WMC Automatic Vane Control (blank mask page)	SET COMP SPs (7) WMC Automatic Vane Control (blank mask page)		SET TOWER SPs (7) Valve Control Range Min = 010% Max = 090%	
	SET UNIT SPs (8) EvapRecTmr = 0.5min EvapPump = #1 ONLY CondPump = #1 ONLY	SET COMP SPs (8) MAX KW = 76.0 Lag Start = 000Sec Step Down = 060Sec	SET COMP SPs (8) MAX KW = 76.0 Lag Start = 000Sec Step Down = 060Sec		SET TOWER SPs (8) PD Control Loop Error Gain = 25 Slope Gain = 25	
	SET UNIT SPs (9) Templifier Src Water No Start = 070°F Delta Reset = 055°F Ignore this menu	SET COMP SPs (9) Protocol =M-BUS MSTR Ident Number= 001 Baud Rate = 19200	SET COMP SPs (9) Protocol =M-BUS MSTR Ident Number= 001 Baud Rate = 19200			
	SET UNIT SPs (10) VFD = YES Min Speed =015%-KW Max Kw = 076.0 Ignore this menu	SET COMP SPs (10) Refrg Sat Pressure Evp Offset =+00.0 psi Cnd Offset = +00.0psi	SET COMP#2 SPs (10) Refrg Sat Pressure Evp Offset =+00.0 psi Cnd Offset = +00.0psi			
	SET UNIT SPs (11) Max Wtr Flow Rates Evap WF=02400GPM CondWF=03000GPM	SET COMP SPs (11) ELWT Offset = +0.0 °F	SET COMP#2 SPs (11) ELWT Offset = +0.0 °F			
	SET UNIT SPs (12) Time Day/Mon/Yr 24 hr time day of wk					
	SET UNIT SPs (13) Display Format Units = °F/psi (IP) Lang = English					
	SET UNIT SPs (14) Protocol = MODBUS Id #= 001 Units =IP Baud Rate = 19200					
	SET UNIT SPs (15) Ex-Val Std Values Pos 450% L76.0psi Enthalpy Sp 85.0°F Ignore this menu					

Selection can then be made by using the LEFT/RIGHT keys to move between columns and the UP/DOWN keys to move between rows.

If the VIEW COMP#2 (3) screen is being viewed and the RIGHT arrow key is pressed, the display will show VIEW EVAP. If the LEFT arrow key is then pressed, the display will show VIEW COMP#2 (3) again (not VIEW COMP (1)).

Attempts to scroll past the limits of the matrix are ignored.

## Screen Definitions – VIEW

The following screens are shown in °F/psi. When the Display Units setpoint is set to °C/kPa, the units of measure on the OITS will change accordingly. The unit and compressor controllers will always be in inches.

### View Unit Status

```
VIEW UNIT STATUS (1)
Unit=COOL
COMP#1 OFF #2 RUN
Ev/Cn Pmps=STRT/RUN
```

Unit states can be OFF, COOL, SHUTDOWN, and ALARM as determined from the Unit State variable, the Unit Mode setpoint, and the presence of a unit shutdown alarm.

Compressor states can be OFF, START, HOLD, LOAD, UNLOAD, SHUTDN, and ALARM as determined from the Comp State variable, the Load and Unload outputs, and the presence of a compressor shutdown alarm.

Evap and Cond Pump states can be OFF, STRT (start), & RUN.

```
VIEW UNIT STATUS (2)
COMP#1 = OFF
Start-Start Tmr Cir
Inhibits-None
```

Inhibits are signals that prevent further loading such as Load Limit, High Discharge Pressure, etc.

```
VIEW UNIT STATUS (3)
COMP#2 = OFF
Start-Start Tmr Cir
Inhibits-None
```

Inhibits are signals that prevent further loading such as Load Limit, High Discharge Pressure, etc.

### View Water Status

```
VIEW UNIT WATER°F(1)
      In   Out  Delta
Evap XX.X XX.X  XX.X
Cond XX.X XX.X  XX.X
```

```
VIEW UNIT WATER°F(2)
      In   Out  Delta
HtRC
Cond XX.X XX.X  XX.X
```

This screen deals with a heat recovery option not currently available on Magnitude units.

```

VIEW UNIT WATER°F(3)
  Water Flow Rates
Evap  =  XXXXX GPM
Cond  =  XXXXX GPM

```

### View Refrigerant Status

```

VIEW UNIT REFRG (1)
      psi    °F
Sat Evap XXX.X  XX.X
Sat Cond XXX.X  XX.X

```

```

VIEW UNIT REFRG (2)
Suct Line  = XXX.X°F
Liquid Line= XXX.X°F
Lift Press =XXXX psi

```

### View Tower Status

Tower Control = Temp/None      Tower Control = Lift

VIEW UNIT TOWER (1) Stages ON = 2 of 4  Setpoint = XXX °F	VIEW UNIT TOWER (1) Stages ON = 2 of 4  Setpoint = XXXX psi
--------------------------------------------------------------------	----------------------------------------------------------------------

The first Stages ON value is the number of fan stages ON. The second number is the Tower Stages setpoint (0 if Tower Control = None).

```

VIEW UNIT TOWER (2)
Bypass Valve = XXX%
VFD Speed    = XXX%

```

The Bypass Valve value is “None” (in place of XXX%) if the Valve/VFD Control setpoint = None or VFD Stage. The VFD Speed value shall be “None” if the Valve/VFD Control setpoint = None, Valve Setpoint, or Valve Stage.

### View Compressor Status

**NOTE:** In the following VIEW COMP screens, the #N field indicates which compressor (#1, or #2,) is being viewed. There are two columns of menus, the first for compressor #1, the second for #2.

```

VIEW COMP#N (1)
State    = RUN
% RLA    = XXX %
Evap LWT =000.0°F

```

State settings can be OFF, START, INTLOK, HOLD, LOAD, UNLOAD, SHUTDOWN, STOP, and ALARM as determined from the Comp State variable, the Load and Unload outputs, and the presence of a compressor shutdown alarm.

```
VIEW COMP#N (2)psi
Cond Press =XXXX
Evap Press =XXXX
Lift Press = XXX
```

```
VIEW COMP#N (3) psi
WMC Compressor
Oilless Design
(blank menu)
```

```
VIEW COMP#N (4) °F
Cavity Temp=XXX.X°F
Invert Temp=XXX.X°C
Lift Temp = XX.X°F
```

```
VIEW COMP#N (5) °F
          Temp  SH
Suction  XXX.X XX.X
DischargeXXX.X XX.X
```

```
VIEW COMP#N (6)
          psi   °F
SatEvap XXX.X XXX.X
SatCond XXX.X XX.X
```

```
VIEW COMP#N (7)
Hours   = XXXXX
Starts = XXXXX
```

The following menus are found only on the compressor controllers and contain detailed information on the compressor operation, used only by trained compressor technicians.

```
VIEW COMP#N (8)
WMC Compressor Rdy
Mode3 Unit0 Float0
Auto Demand 000.0KW
```

```
VIEW COMP#N (9)RPM
Min=00000 Act=00000
Max=00000 Des=00000
Ver=419 Serial=0000
```

```
VIEW COMP#N(10)Alrms
Ctl-----
BearingF-00000A00000
Motor F-00000A00000
```

```
VIEW COMP#N (11)Pwr
L1=458V 000.0Amps
L2=458V 000.0Amps
L3=458V 000.0Amps
```

```
VIEW COMP#N(12)Bear
FX 00000 RX 00000
FY 00000 RY 00000
AX 00000 Ver3939 Off
```

```
VIEW COMP#N(13)S-Str
UpTrp=0530 Vdrp 0000
DnTrp=0380 RxV 0654
Ver=00136 Ok SCR-On
```

```
VIEW COMP#N (14) Psi
IGV=020.0 DisC=082.6
024.9 Suct=081.9
00000Alr Intr=000.0
```

```
VIEW COMP#N(15)Temps
Suct=89.4 Cav=093.9
SCR=090.8 Ent=077.4
Disc=090.7 Lev=077.4
```

```
VIEW COMP#N(16)Motor
S_SP 0017
Spdly 0000
Inv_Temp 031.0 deg C
```

### View Vessel Status

```
VIEW EVAPORATOR
Suct SH = XXX.X °F
Approach = XX.X °F
```

Press right arrow to view the condenser data.

```
VIEW CONDENSER
Disch SH = XXX.X °F
Approach = XX.X °F
Subcooling= XX.X °F
```

## View Alarms

```
ALARM LOG 01
Description
hh:mm:ss dd/mmm/yyyy
```

```
ALARM LOG 02 to 25
Description
hh:mm:ss dd/mmm/yyyy
```

```
ACTIVE ALARM
Time      Date
Fault Description
```

## Set Unit Setpoints

The following screens are only shown in °F/psi. Setpoint default values and available setting range can be found in Table 6 on page 20.

```
SET UNIT SPs (1)
Unit Enable = OFF
Unit Mode   = COOL
Source     = SWITCHES
```

Unit Enable settings can be OFF and ON as determined from the Unit Enable setpoint.

Unit Mode settings can be COOL or TEST as determined from the Unit Mode setpoint (TEST mode is not selectable from the 4x20 display/keypad although it may be displayed if already set).

Source settings can be KEYPAD, SWITCHES, or NETWORK as determined from the Mode Source setpoint.

```
SET UNIT SPs (2)
Available Modes
= COOL
Select w/Unit Off
```

Available Modes settings for Magnitude chillers can be COOL. The unit must be turned off to change this setpoint.

```
SET UNIT SPs (3)
Cool LWT = XX.X°F
Ice LWT  = XX.XF
Heat LWT = XX.XF
```

Ignore any setting other than COOL LWT should they appear on this menu.

```
SET UNIT SPs (4)
Leaving Water Temp
StartDelta= 03.0°F
StopDelta = 03.0°F
```

```
SET UNIT SPs (5)
```

```
Reset Type =none
MaxResetDT =XX.X°F
StrtResetDT=XX.X°F
```

Reset Type settings can be NONE, RETURN, or 4-20 as determined by the LWT Reset Type setpoint.

```
SET UNIT SPs (6)
Soft Load = OFF
BeginAmpLimit=40%
SoftLoadRamp=05min
```

Soft Load settings can be OFF or ON as determined from the Soft Load setpoint.

```
SET UNIT SPs (7)
Max/Min LWT Rates
  Max = 0.5°F/min
  Min = 0.1°F/min
```

### Pump Selection

```
SET UNIT SPs (8)
EvapRecTmr =X.Xmin
EvapPump = #1 ONLY
CondPump = #2 PRIM
```

The Evaporator Water Pump outputs will be controlled in a Primary/Standby manner according to the Evap Pump setpoint which may be set to #1 Only, #2 Only, Auto, #1 Primary/#2 Standby, or #2 Primary/#1 Standby.

- If #1 Only is selected, only pump #1 will be started even in event of a failure.
- If #2 Only is selected, only pump #2 will be started.
- If Auto is desired, the unit will try to balance operating hours on each pump by starting the pump with the least amount of operating hours first. In case of pump failure, the unit will start the backup pump.
- In standby mode, the primary pump will always be started first. The standby pump will only be started if there is a failure indicated on the primary pump.

An Evaporator Water Pump output will be ON if the Evap State is set to START or RUN. Both outputs will be OFF if the Evap State is set to OFF.

```
SET UNIT SPs (9)
Templifier Scr Water
No Start =070°F
Delta Reset=055°F
```

This menu does not apply to Magnitude chillers and should be ignored.

```
SET UNIT SPs (10)
VFD = Yes
Min Speed = XXX%
Max Kw = 076.0
```

VFD settings are controlled by the compressor on-board microprocessor and these settings are not used.

```
SET UNIT SPs (11)
Max Wtr Flow Rates
Evap WF = 02400 GPM
Cond WF = 03000 GPM
```

These settings are used to calibrate customer-supplied flow switches.

```
SET UNIT SPs (12)
  STD/Day Light Time
    dd/mmm/yyyy
hh:mm:ss Day of week
```

```
SET UNIT SPs (13)
Display Format
Units = °F/psi (IP)
Lang = English
```

```
SET UNIT SPs (14)
Protocol = Modbus
Id#= 001 Units=IP
Baud Rate = 19200
```

```
SET UNIT SPs (15)
EX-Val Std Values
Pos 450% L76.0psi
Enthalpy Sp 85.0°F
```

### Set Compressor Setpoints

NOTE: In the following SET COMP screens, the #N field indicates which compressor (#1 or #2 ) is being set. There is basically a column of menu screens for each compressor.

```
SET COMP#N SPs (1)
Demand Limit = OFF
Minimum Amps = 010%
Maximum Amps = 100%
```

Demand Limit settings can be OFF or ON as determined from the Demand Limit setpoint.

```
SET COMP#N SPs (2)
StageMode = NORMAL
StageSequence# =01
  Max Compr ON =02
```

StageMode settings can be NORMAL, HI EFF, PUMP, and STANDBY as determined by the Stage Mode setpoint.

NORMAL has the auto-balance sequence that starts compressors with least starts and stops compressors with most hours, in sequence, providing all compressors have the same sequence number. If they have different sequence numbers, say 1, 2, 3, 4; they will always start in that sequence. That is, sequence number will take precedence over auto-balance sequencing.

HI EFF is used with multiple chillers and runs one compressor per chiller when ever possible.

PUMP starts all compressors on the same chiller first, starting with the chiller with the compressor with the least starts (or by sequence number if they are different).

STANDBY is used in multi-compressor systems and reserves a compressor to come on only if there is a failure of another compressor in the system and the standby compressor capacity is required to maintain chilled water temperature.

StageSequence is set for each compressor:

- In NORMAL or STANDBY Mode, all compressors can have the same number or a number from 1 up to the total number of compressors. Sequence number has priority over other considerations. If four compressors in a system are given the sequence numbers 1 through 4, they will always start in that order. With the same number they will auto-sequence.
- In HI EFF or PUMP Mode, all compressors must have the same sequence number.
- Max Compr ON limits the number of compressors allowed to run in multi-compressor systems. It provides a "floating standby" compressor. All compressor controllers must have the same setting for this setpoint.

```
SET COMP#N SPs (3)
StageDeltaT =1.0°F
  Stop-Start =03min
  Start-Start =40min
```

```
SET COMP#N SPs (4)
Full Load = 300sec
Name Plate RLA 085
```

Full Load timing is one of several "full load flags," parameters that indicate a compressor is at full load.

```
SET COMP#N SPs (5)

Nom Capacity=0100T
Hotgasbypass =
```

Ignore hot gas bypass setting. Magnitude chillers are not so equipped.

```
SET COMP#N SPs (6)
IntrLokTmr=010sec
UnloadTimer=030sec
Max Str LWT = XXX°F
```

Ignore Max Str LWT setting.

```
SET COMP#N (7)
  WMC Automatic
  Vane Control
(blank menu)
```

Ignore this menu on Magnitude chillers.

```
SET COMP#N (8)
  MAX KW = 076.0
Lag Start = 000Sec
Step Down = 060Sec
```

## Staging Parameters

### Full Load Determination

Each compressor determines if it is at its maximum capacity (or maximum allowed capacity) and, if so, set its Full Load flag. The flag advises other components that the compressor is fully loaded. The flag is set (full load) when one or more of the following conditions are met.

- The compressor is at its physical limit of capacity which means:

For VFD Set Point = NO: The load output has been pulsed ON for a cumulative time equal to or greater than the Full Load set point (menu #4). Any unload pulse will reset the cumulative time to zero.

For VFD Set Point = YES: Load pulsing has exceeded the Full Load set point (as described above) AND the VFD speed = 100%

OR

The Vanes Open digital input is On AND the VFD speed = 100%.

- The % RLA is above or equals the Maximum Amp limit set point.
- The % RLA is above or equals the Demand Limit analog input value
- The % RLA is above or equals the Network Limit value
- The evaporator pressure is below the Low Evap Pressure-Inhibit set point.

When none of the above conditions are met, the Full Load flag is cleared.

### Absolute Capacity

Each compressor estimates its absolute capacity from the present value of %RLA and the Absolute Capacity set point from the equation:

Absolute Capacity = (% RLA Factor) \* (Absolute Capacity set point)

Where the % RLA Factor is interpolated from the following table.

% RLA	0	50	75	100	150
% RLA Factor	0	0.35	0.75	1.00	1.50

```
SET COMP#N (9)
Protocol =M-BUS MSTR
Ident Number= 001
Baud Rate = 19200
```

SET COMP#N (10)  
Refrg Sat Pressure  
Evp Offset=+00.0psi  
Cnd Offset=+00.0psi

SET COMP#N (11)  
ELWT Offset=+00.0°F

### Set Alarm Limits

SET ALARM LMTS (1)  
LowEvPrHold=33psi  
LowEvPrUnld=31psi  
LowEvPrStop=29psi

SET ALARM LMTS (2)  
HighCondPr = 140psi  
HiDschT-Load=170°F  
HiDschT-Stop=190°F

SET ALARM LMTS (3)  
WMC Compressor  
Oilless Design  
(blank mask page)

SET ALARM LMTS (4)  
Surge Slp Str=20°F  
Surge Tmp Run=12°F  
MtrCurrThrshld=05%

### CAUTION

Only trained compressor technicians should set these setpoints.

SET ALARM LMTS (5)  
Evap Freeze=34.0°F  
Cond Freeze=34.0°F

### Set Tower Setpoints

SET TOWER SPs (1)  
TowerControl = None  
Tower Stages = 2  
StageUP/DN=080/020%

Tower control settings can be None, Temp, or Lift.

**Tower Control = Temp/None      Tower Control = Lift**

<b>SET TOWER SPs (2)</b>	<b>SET TOWER SPs (2)</b>
<b>Stage ON (Temp)°F</b>	<b>Stage ON (Lift)psi</b>
<b>  #1  #2  #3  #4</b>	<b>  #1  #2  #3  #4</b>
<b>  XXX XXX XXX XXX</b>	<b>  XXX XXX XXX XXX</b>

**Tower Control = Temp/None      Tower Control = Lift(psi)**

<b>SET TOWER SPs (3)</b>	<b>SET TOWER SPs (3)</b>
<b>StageDiff = XX.X°F</b>	<b>StageDiff =XX.Xpsi</b>
<b>Stage Up = XX min</b>	<b>Stage Up = XX min</b>
<b>StageDown = XX min</b>	<b>StageDown = XX min</b>

<b>SET TOWER SPs (4)</b>
<b>Valve/VFD Control=</b>
<b>  ValveSP/VFDStage</b>
<b>Valve Type = NC</b>

Valve/VFD Control settings are None, Valve Setpoint, Valve Stage, VFD Stage, or ValveSP/VFDStage. Valve Type settings are NC (normally closed to tower) or NO (normally open).

**Tower Control = Temp/None      Tower Control = Lift**

<b>SET TOWER SPs (5)</b>	<b>SET TOWER SPs (5)</b>
<b>Valve SP = XXX °F</b>	<b>Valve SP = XXX psi</b>
<b>Valve DB = XX.X °F</b>	<b>Valve DB = XXX.Xpsi</b>

<b>SET TOWER SPs (6)</b>
<b>ValveStartPosition</b>
<b>  Min = 010% @ 060°F</b>
<b>  Max = 100% @ 090°F</b>

<b>SET TOWER SPs (7)</b>
<b>Valve Control Range</b>
<b>  Min = 010%</b>
<b>  Max = 100%</b>

<b>SET TOWER SPs (8)</b>
<b>PD Control Loop</b>
<b>  Error Gain = 25</b>
<b>  Slope Gain = 25</b>

Tower fan control is active when the Tower Control setpoint is set to Temperature or Lift and the condenser pump is in the RUN state. Staging is based on either Entering Condenser Water Temperature (ECWT) or Lift pressure as selected by the Tower Control setpoint. Operation depends on the following parameters.

- Condenser pump state
- ECWT OR Lift pressure
- Stage up and stage down timer values
- Tower setpoints (Tower Control, Tower Stages, Stage Up Time, Stage Down Time, Stage Differential (Temp OR Lift), Stage #1 ON (Temp OR Lift), Stage #2 ON (Temp OR Lift), Stage #3 ON (Temp OR Lift), Stage #4 ON (Temp OR Lift), Stage Down @, Stage Up @)

The stage up timer starts when the condenser pump starts. The first stage turns ON when the following conditions are met:

- The stage up timer completes
- The ECWT is > Stage #1 ON (Temp) setpoint (only if the Tower Control setpoint = Temperature)
- The Lift pressure is > Stage #1 ON (Lift) setpoint (only if the Tower Control setpoint = Lift)
- Bypass valve position is > the Stage Up @ setpoint (only if Valve/VFD Control setpoint = Valve Stage)

Additional stages can turn on (up to the number specified by the Tower Stages setpoint) when above conditions are met for the next stage plus the following condition:

- VFD Speed is > the Stage Up @ setpoint (only if Valve/VFD Control setpoint = VFD Stage OR Valve SP/VFD Stage)

Down staging occurs when the the following conditions are met:

- The stage down timer completes
- The ECWT is < Stage #X ON (Temp) setpoint – Stage Differential (Temp) setpoint point (only if the Tower Control setpoint = Temperature).
- The Lift pressure is < Stage #X ON (Lift) setpoint – Stage Differential (Lift) setpoint point (only if the Tower Control setpoint = Lift)
- Bypass valve position is < the Stage Down @ setpoint (only if Valve/VFD Control setpoint = Valve Stage)
- VFD Speed is < the Stage Down @ setpoint (only if Valve/VFD Control setpoint = VFD Stage OR Valve SP/VFD Stage)

Each stage up or stage down event restarts both the stage up and stage down timers. Only one fan output is switched at a time (except that all outputs switch OFF when the condenser pump state equals OFF).

### Analog Output Control

Each analog output is controlled according to the following rules/algorithms and in accordance with whether the Compressor Mode setpoint is set to AUTO or MANUAL (normal operation) or TEST (test mode). All outputs are initialized to 0 at power on.

### Cooling Tower Bypass Valve

When the Valve/VFD Control setpoint is set to None OR VFD Stage, this output is set to 0. Otherwise, it is controlled as described below.

### Initial Valve Position

When the condenser pump is not in the RUN state, the valve output is set as a function of entering condenser water temperature (ECWT) per the following graph.

**Figure 34, Bypass Valve Position**

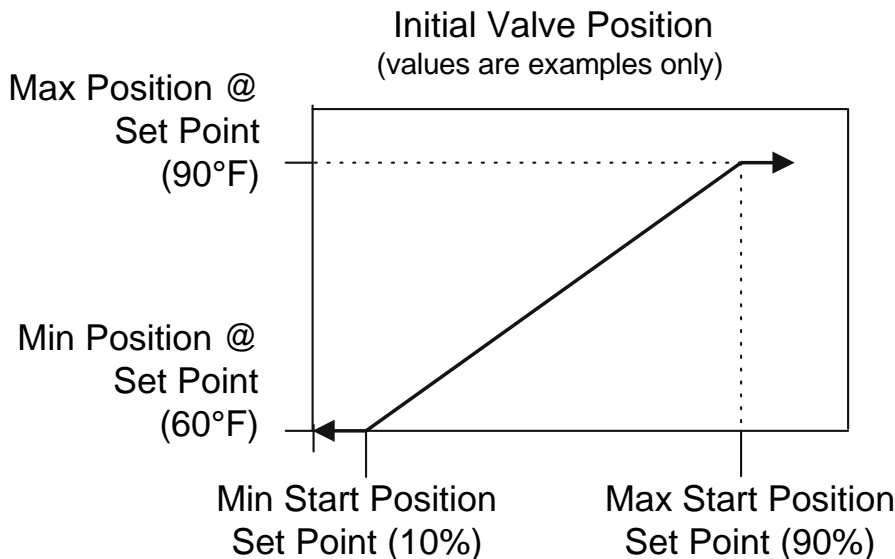

### Normal Operation

When the condenser pump is in the RUN state, the valve output is controlled in one of two modes as specified by the Valve/VFD Control setpoint. The controlled parameter (CP) is either ECWT or Lift as specified by the Tower Control setpoint. When the desired output signal varies from 0 to 100%, the output voltage will vary as follows.

- 0 to 10 VDC (Valve Type = NC to tower)
- 10 to 0 VDC (Valve Type = NO to tower)

### Valve Setpoint Mode

This mode is operational when the Valve/VFD Control setpoint is set to Valve Setpoint OR Valve SP/VFD Stage. In this mode the valve output is varied with a proportional-derivative (PD) algorithm (with deadband) in order to maintain the controlled parameter (CP) at the desired value. The output is always limited between the Valve Control Range (Min) setpoint and the Valve Control Range (Max) setpoint. A valve increment is computed once every 5 seconds according to the following equation.

- $\text{Increment} = [(\text{Error}) * (\text{Error Gain setpoint})] + [(\text{Slope}) * (\text{Slope Gain setpoint})]$
- Where: Error = ECWT – Valve Setpoint (Temp), (only if Tower Control setpoint = Temperature)
- Error = Lift – Valve Setpoint (Lift), (only if Tower Control setpoint = Lift)
- Slope = (Present CP) – (Previous CP)

When the Error is > the Valve Deadband (Temp OR Lift as appropriate) setpoint, the valve position analog output (% of full scale) is updated according to the following equation.

- $\text{New \%Position} = \text{Old \%Position} + \text{Increment}/10.$

### Valve Stage Mode

This mode is only operational when the Valve/VFD Control setpoint is set to Valve Stage. In this mode the valve output is controlled as for Valve Setpoint mode (above), except that the active setpoint for the controlled parameter is selected according to the following table.

**Table 25, Valve Staging**

# Of Fans ON	Active Setpoint
0	Valve Setpoint (Temp OR Lift as appropriate)
1	Stage #1 ON (Temp OR Lift as appropriate)
2	Stage #2 ON (Temp OR Lift as appropriate)
3	Stage #3 ON (Temp OR Lift as appropriate)
4	Stage #4 ON (Temp OR Lift as appropriate)

## Cooling Tower Fan VFD

### Normal Operation

When the Valve/VFD Control setpoint is set to None, Valve Setpoint, OR Valve Stage, this output is set to 0. Otherwise, it shall be controlled in a manner identical to Valve Stage Mode (above) except that (1) it is kept at zero until the first fan stage is ON and (2) the following setpoints do not apply.

- Valve Control Range (Min)
- Valve Control Range (Max)
- Valve Type

### Editing

Editing is accomplished by pressing the ENTER (lower-right key) key until the desired field is selected. This field is indicated by a blinking cursor under it. The arrow keys then operate as follows:

- CANCEL (⇒ Key)                      Reset the current field to the value it had when editing began.
- DEFAULT (⇐ Key)                      Set value to original factory setting.
- INCREMENT (↑ Key)                    Increase the value or select the next item in a list.
- DECREMENT (↓ Key)                    Decrease the value or select the previous item in a list.

During edit mode, the display shows a two-character wide menu pane on the right as shown below.

SET UNIT SPs (X)	<D
(data)	<C
(data)	<+
(data)	<-

Additional fields can be edited by pressing the ENTER key until the desired field is selected. When the last field is selected, pressing the ENTER key switches the display out of “edit” mode and returns the arrow keys to “scroll” mode.

## Alarms

When an alarm occurs, the alarm type, date, and time are stored in the active alarm buffer corresponding to that alarm (viewed on the Alarm Active screens) and also in the alarm log buffer (viewed on the Alarm Log screens). The active alarm buffers hold a record of the last occurrence of each alarm and whether or not it has been cleared. The alarm can be cleared by pressing the Edit key. A separate buffer is available for each alarm (High Cond Pressure, Evaporator Freeze Protect, etc.) The alarm history buffer holds a chronological account of the last 25 alarms of any type.

## Display Languages

Languages currently available are:

- English

## Units of Measure

It is possible to select units of measure directly from the keypad. Systems available are:

- °F / psi: unit controller, compressor controller, touch screen
- °C / kPa: touch screen only

## Security

Two four-digit passwords provide OPERATOR and MANAGER levels of access to changeable parameters. Either password can be entered using the ENTER PASSWORD screen which can be accessed in one of three ways:

1. The SET UNIT SPs menu
2. Scrolling to it (last screen in the SET UNIT SPs column)
3. By simply pressing the UP ARROW, DOWN ARROW, or DEFAULT keys while on the desired field on one of the SET screens. The password can then be entered by pressing the ENTER key, scrolling to the correct value with the UP and DOWN arrow keys, and pressing ENTER again. The length of the password shall not be indicated. Once the correct password has been entered (cases 1 and 2 above), the PASSWORD screen shall show the active password level. For case 3 above, the previously selected screen shall reappear (still in edit mode) with the cursor on the previously selected field. Once a password has been entered, it shall remain valid for 15 minutes after the last key-press. It shall be possible to change the passwords through multi-chiller communications. Parameters and screens that require the MANAGER password shall not be displayed unless the MANAGER password is active.

# Compressor Controller Menu Screens

## Menu Matrix

Each of the two compressor controllers has the same menu screens, as shown in the following matrix.

**NOTE:** All relevant unit operating data and setpoint entry are available and performed on the unit controller and there is no need to consult the individual compressor controllers. The following table is for general information only.

VIEW STATUS SCREENS					
VIEW UNIT STATUS(1) UNIT= OFF COMP OFF Ev/Cn Pmps=OFF/OFF	VIEW UNIT WATER(1)°F In Out Delta Evap 00.0 00.0 00.0 Cond 00.0 00.0 00.0	VIEW UNIT REFRG (1) psi °F Sat Evap 000.0 000.0 Sat Cond 000.0 000.0	VIEW COMP (1) State = OFF % RLA = 000% Evap LWT = 054.0°F	VIEW EVAPORATOR Suct SH = 000.0°F Approach = 00.0°F	VIEW CONDENSER Disch SH = 000.0°F Approach = 00.0°F Subcooling = 00.0°F
VIEW UNIT STATUS(2) Comp OFF Start-Start Tmr Clr Inhibits None		VIEW UNIT REFRG (2) Suct Line = 000.0°F Liquid Line = 000.0°F Lift Press = 000.0psi	VIEW COMP (2) psi Cond Press = 000.0 Evap Press = 000.0 Lift Press = 000.0		
			VIEW COMP (3) psi WMC Compressor Oilless Design (blank menu)		
			VIEW COMP (4) °F Cavity Temp=000.0°F Invert Temp=000.0°C Lift Temp = 00.0°F		
			VIEW COMP (5) °F Temp SH Suction 000.0 00.0 Discharge 000.0 00.0		
			VIEW COMP (6) psi °F SatEvap 000.0 000.0 SatCond 000.0 000.0		
			VIEW COMP (7) Hours = 00000 x10 Starts = 00000		

**NOTE:** Right half of matrix continued on the next page.

SET SETPOINTS		
SET COMP#1 SPs (1) Demand Limit=OFF Minimum Amps=040% Maximum Amps=100%	SET ALARM LMTs (1) LowEvPrHold=33psi LowEvPrUnld=31psi LowEvPrStop=29psi	SET PASSWORD Enter Password:00000 No Access Given
SET COMP SPs (2) StageMode =Normal StageSequence# = 01 Max Compr ON = 01	SET ALARM LMTs (2) HighCondPr =140psi HiDschT-Load=170°F HiDschT-Stop=190°F	SET PASSWORD (2) Tech Password 00000 00000 No Access Given
SET COMP SPs (3) StageDeltaT = 1.0°F Stop-Start = 03 min Start-Start = 40 min	SET ALARM LMTs (3) WMC Compressor Oilless Design (blank mask page)	
SET COMP SPs (4) Full Load = 300 sec Name Plate RLA 085	SET ALARM LMTs (4) Surge Slp Str=20°F Surge Tmp Run=06°F MtrCurThrshld=10%	
SET COMP SPs (5) Nom Capacity = 0100T HotGasBypass = 30%	SET ALARM LMTs (5) Evap Freeze= 34.0°F Cond Freeze= 34.0°F	
SET COMP SPs (6) InterLokTmr= 010sec UnloadTimer = 030 sec		
SET COMP SPs (7) WMC Automatic Vane Control (blank mask page)		
SET COMP SPs (8) MAX KW = 76.0 Lag Start = 000Sec Step Down = 060Sec		
SET COMP SPs (9) Protocol =M-BUS MSTR Ident Number= 001 Baud Rate = 19200		
SET COMP SPs (10) Refrg Sat Pressure Evp Offset =+00.0 psi Cnd Offset = +00.0psi		
SET COMP SPs (11) ELWT Offset = +0.0 °F		

# BAS Interface

---

The MicroTech II controller is available with the optional Open Choices™ feature, an exclusive McQuay feature that provides easy integration with a building automation system (BAS). If the unit will be tied into a BAS, the controller should have been purchased with the correct factory-installed communication module. The modules can also be added in the field during or after installation.

If an interface module was ordered, one of the following BAS interface installation manuals was shipped with the unit. Contact your local McQuay sales office for a replacement, if necessary.

- IM 735, LONWORKS® Communication Module Installation
- IM 736, BACnet® Communication Module Installation
- IM 743, Modbus® Communication Module Installation

## Connection to Chiller

Connection to the chiller for all BAS protocols will be at the unit controller. An interface card will have to be installed in the unit controller depending on the protocol being used.

# Maintenance

## **⚠ DANGER**

Wait 10 minutes after compressor shutdown before opening any compressor access panel.  
The DC link capacitors store enough energy to cause electrocution.

## Pressure/Temperature Chart

R-134a Temperature Pressure Chart							
°F	PSIG	°F	PSIG	°F	PSIG	°F	PSIG
6	9.7	46	41.1	86	97.0	126	187.3
8	10.8	48	43.2	88	100.6	128	192.9
10	12.0	50	45.4	90	104.3	130	198.7
12	13.2	52	47.7	92	108.1	132	204.5
14	14.4	54	50.0	94	112.0	134	210.5
16	15.7	56	52.4	96	115.9	136	216.6
18	17.1	58	54.9	98	120.0	138	222.8
20	18.4	60	57.4	100	124.1	140	229.2
22	19.9	62	60.0	102	128.4	142	235.6
24	21.3	64	62.7	104	132.7	144	242.2
26	22.9	66	65.4	106	137.2	146	249.0
28	24.5	68	68.2	108	141.7	148	255.8
30	26.1	70	71.1	110	146.3	150	262.8
32	27.8	72	74.0	112	151.1	152	270.0
34	29.5	74	77.1	114	155.9	154	277.3
36	31.3	76	80.2	116	160.9	156	284.7
38	33.1	78	83.4	118	166.0	158	292.2
40	35.0	80	86.7	120	171.1	160	299.9
42	37.0	82	90.0	122	176.4	162	307.8
44	39.0	84	93.5	124	181.8	164	315.8

## Routine Maintenance

### Refrigerant Cycle

Maintenance of the refrigerant cycle includes maintaining a log of the operating conditions and checking that the unit has the proper refrigerant charge.

At every inspection, the suction, and discharge pressures should be noted and recorded, as well as condenser and chiller water temperatures.

The suction line temperature at the compressor should be taken at least once a month. Subtracting the saturated temperature equivalent of the suction pressure from this will give the suction superheat. Extreme changes in subcooling and/or superheat over a period of time will indicate losses of refrigerant or possible deterioration or malfunction of the expansion valve. The evaporator operates at 0° to 1° F (0.5° C) of superheat through most of the load range. The refrigerant used for compressor cooling dumps at the compressor suction, where the suction temperature sensor is located. This results in a warming of the suction gas and superheat readings of 4° to 5° F (2° to 3° C).

The discharge superheat should be between 16° and 18° F (9° to 10° C) and remains fairly constant through most of the load range.

Liquid subcooling is in the range of 8° to 9° F (4.5° to 5.0° C).

The MicroTech II operator interface touch-screen panel can display all superheat and subcooling temperatures.

## Electrical System

Maintenance of the electrical system involves the general requirement of keeping contacts clean and connections tight and checking on specific items as follows:

The compressor current draw should be checked and compared to nameplate RLA value. Normally, the actual current will be lower, since the nameplate rating represents full load operation. Also check all pump and fan motor amperages, and compare with nameplate ratings.

At least once a quarter, all equipment protection controls, except compressor overloads, should be made to operate and their operating points checked. A control can shift its operating point as it ages, and this must be detected so the controls can be adjusted or replaced. Pump interlocks and flow switches should be checked to be sure they interrupt the control circuit when tripped.

## Cleaning and Preserving

A common cause of service calls and equipment malfunction is dirt. This can be prevented with normal maintenance. The system components most subject to dirt are:

1. Permanent or cleanable filters in the air handling equipment must be cleaned in accordance with the manufacturer's instructions; throwaway filters should be replaced. The frequency of this service will vary with each installation.
2. Remove and clean strainers in the chilled water system and condenser water system at every inspection.
3. Inspect the condenser tubes annually for fouling and clean if required. The dished water heads (aka end-bells, water boxes) should be removed with care due to their weight. One method follows:
  - After draining water, remove all but two head bolts at roughly 10 and 2 o'clock.
  - Loosen the remaining two bolts to enable the head to be separated from the tube sheet sufficiently for a clevis pin or hook to be inserted into an open bolt hole at the top of the head.
  - Attach a hoist to the pin or hook, lift the head to remove weight from the two remaining bolts, remove the bolts and carefully remove the head.
  - Do not try to install a machine thread eyebolt into the head vent fitting, which has pipe threads.
  - Reverse this procedure to mount the head, using a new gasket.

## Water Treatment

Make sure tower blowdown or bleed-off is operating. Set up and use a good maintenance program to prevent "liming up" of both tower and condenser. It should be recognized that atmospheric air contains many contaminants that increase the need for proper water treatment. The use of untreated water can result in corrosion, erosion, sliming, scaling or algae formation. It is recommended that the service of a reliable water treatment company be used. McQuay International assumes no responsibility for the results of untreated or improperly treated water.

## Repair of System

### Pressure Relief Valve Replacement

Current condenser designs use two relief valves separated by a three-way shutoff valve (one set). This three-way valve allows either relief valve to be shut off, but at no time can both be shut off. In the event one of the relief valves are leaking in the two valve set, these procedures must be followed:

- If the valve closest to the valve stem is leaking, back seat the three-way valve all the way, closing the port to the leaking pressure relief valve. Remove and replace the faulty relief valve. The three-way shutoff valve must remain either fully back seated or fully forward to normal operation. If the relief valve farthest from the valve stem is leaking, front seat the three-way valve and replace the relief valve as stated above.
- The refrigerant must be pumped down into the condenser before the evaporator relief valve can be removed.

## Pumping Down

If it becomes necessary to pump the system down, extreme care must be used to avoid damage to the evaporator from freezing. Always make sure that full water flow is maintained through the chiller and condenser while pumping down. To pump the system down, close all liquid line valves. With all liquid line valves closed and water flowing, start the compressor. Set the MicroTech II control to the manual load. The vanes must be open while pumping down to avoid a surge or other damaging condition. Pump the unit down until the MicroTech II controller cuts out at approximately 20 psig. It is possible that the unit might experience a mild surge condition prior to cutout. If this should occur, immediately shut off the compressor. Use a portable condensing unit to complete the pump down, condense the refrigerant, and pump it into the condenser or pumpout vessel using approved procedures.

## Pressure Testing

No pressure testing is necessary unless some damage was incurred during shipment. Damage can be determined by a visual inspection of the exterior piping, checking that no breakage occurred or fittings loosened. Service gauges should show a positive pressure. If no pressure is evident on the gauges, a leak may have occurred, discharging the entire refrigerant charge. In this case, the unit must be leak tested to determine the location of the leak.

## Leak Testing

In the case of loss of the entire refrigerant charge, the unit must be checked for leaks prior to charging the complete system. This can be done by charging enough refrigerant into the system to build the pressure up to approximately 10 psig (69 kPa) and adding sufficient dry nitrogen to bring the pressure up to a maximum of 125 psig (860 kPa). Leak test with an electronic leak detector. Halide leak detectors do not function with R-134a. Water flow through the vessels must be maintained anytime refrigerant is added or removed from the system.

### WARNING

Do not use oxygen or a mixture of a refrigerant and air to build up pressure as an explosion can occur causing serious personal injury.

If any leaks are found in welded or brazed joints, or it is necessary to replace a gasket, relieve the test pressure in the system before proceeding. Brazing is required for copper joints.

After making any necessary repair, evacuate the system as described in the following section.

## Evacuation

After it has been determined that there are no refrigerant leaks, the system must be evacuated using a vacuum pump with a capacity that will reduce the vacuum to **at least 1000 microns of mercury**.

A mercury manometer or an electronic or other type of micron gauge must be connected at the farthest point from the vacuum pump. For readings below 1000 microns, an electronic or other micron gauge must be used.

The triple evacuation method is recommended and is particularly helpful if the vacuum pump is unable to obtain the desired 1 millimeter of vacuum. The system is first evacuated to approximately 29 inches of mercury. Dry nitrogen is then added to the system to bring the pressure up to zero pounds.

Then the system is once again evacuated to approximately 29 inches of mercury. This is repeated three times. The first pulldown will remove about 90% of the noncondensables, the second about 90% of that remaining from the first pulldown and, after the third, only 1/10-1% noncondensables will remain.

## Charging the System

McQuay water chillers are leak tested at the factory and shipped with the correct charge of refrigerant as indicated on the unit nameplate. In the event the refrigerant charge was lost due to shipping damage, charge system as follows after first repairing the leaks and evacuating the system.

1. Connect the refrigerant drum to the gauge port on the liquid line shutoff valve and purge the charging line between the refrigerant cylinder and the valve. Then open the valve to the mid-position.
2. Turn on both the cooling tower water pump and chilled water pump and allow water to circulate through the condenser and the chiller. (It may be necessary to manually close the condenser pump starter.)
3. If the system is under a vacuum, stand the refrigerant drum with the connection up, and open the drum and break the vacuum with refrigerant gas to a saturated pressure above freezing.
4. With a system gas pressure higher than the equivalent of a freezing temperature, invert the charging cylinder and elevate the drum above the condenser. With the drum in this position, valves open, water pumps operating, liquid refrigerant will flow into the condenser. Approximately 75% of the total requirement estimated for the unit can be charged in this manner.
5. After 75% of the required charge has entered the condenser, reconnect the refrigerant drum and charging line to the service valve on the bottom of the evaporator. Again purge the connecting line, stand the drum with the connection up, and place the service valve in the open position.

### CAUTION

**IMPORTANT:** At this point, the charging procedure should be interrupted and prestart checks made before attempting to complete refrigerant charge. The compressor must not be started at this time.

(Preliminary check must first be completed.)

---

**NOTE:** It is of utmost importance that all local, national, and international regulations concerning the handling and emission of refrigerants are observed.

---

# Maintenance Schedule

	Monthly	Quarterly	Semi-Annually	Annually	As Required By Performance
<b>I. Compressor</b>					
A. Performance Evaluation (Log & Analysis) *	O				
B. Motor					
• Ampere Balance (within 10%)		X			
• Terminal Check (tight connections, porcelain clean)				X	
• Motor Cooling (check temperature)		X			
C. Vane Operation					
• Compressor Loads:					
Operate Manual Switch		X			
Record Motor Amps		X			
• Compressor Unloads:					
Operate manual Switch		X			
Record Motor Amps		X			
• Vanes Will Hold (place manual switch in "hold")					
Observe Water Temp and Record Amps		X			
D. Internal Compressor Check					X
<b>II. Controls</b>					
A. Operating Controls					
• Check Settings and Operation			X		
• Check Vane Control Setting and Operation			X		
• Verify Motor Load Limit Control			X		
• Verify Load Balance Operation			X		
B. Protective Controls					
• Test Operation of:					
Alarm Relay		X			
Pump Interlocks		X			
<b>III. Condenser</b>					
A. Performance Evaluation	O				
B. Test Water Quality		X			
C. Clean Condenser Tubes				X	
D. Eddy current Test - Tube Wall Thickness					X
E. Seasonal Protection					X
<b>IV. Evaporator</b>					
A. Performance Evaluation (Log Conditions And Analysis)	O				
B. Test Water Quality		X			
C. Clean Evaporator Tubes (as required)					X
D. Eddy current Test - Tube Wall thickness (as required)					X
E. Seasonal Protection					X
<b>V. Expansion Valve</b>					
A. Performance Evaluation (Superheat Control)		X			
<b>VI. Compressor - Chiller Unit</b>					
A. Performance Evaluation	O				
B. Leak Test:					
• Compressor Fittings and Terminal		X			
• Piping Fittings		X			
• Vessel Relief Valves		X			
C. Vibration Isolation Test		X			
D. General Appearance:					
• Paint				X	
• Insulation				X	
<b>VII. Electrical</b>					
A. Capacitors, Replace every 10 years from startup, include bus bar. Consult McQuay for parts and instructions.					

Key: O = Performed by in-house personnel X = Performed by McQuay Service personnel

## Service Programs

---

It is important that an air conditioning system receive adequate maintenance if the full equipment life and full system benefits are to be realized.

Maintenance should be an ongoing program from the time the system is initially started. A full inspection should be made after 3 to 4 weeks of normal operation on a new installation and on a regular basis thereafter.

McQuay offers a variety of maintenance services through the local McQuay Factory Service office, its worldwide service organization, and can tailor these services to suit the needs of the building owner. Most popular among these services is the McQuay Comprehensive Maintenance Contract.

For further information concerning the many services available, contact your local McQuay Factory Service office.

## Operator Schools

---

Training courses for Magnitude Centrifugal Maintenance and Operation are held through the year at the McQuay Training Center in Staunton, Virginia. The school duration is three and one-half days and includes instruction on basic refrigeration, MicroTech II controllers, enhancing chiller efficiency and reliability, MicroTech II troubleshooting, system components, and other related subjects. Further information can be found by visiting [www.mcquay.com](http://www.mcquay.com) and clicking on the Training link, or by calling McQuay at 540-248-0711 and ask for the Training Department.

## Limited Warranty

---

Consult your local McQuay Representative for warranty details. Refer to Form 933-43285Y. To find your local McQuay Representative, go to [www.mcquay.com](http://www.mcquay.com).







This document contains the most current product information as of this printing. For the most up-to-date product information, please go to [www.mcquay.com](http://www.mcquay.com). All McQuay equipment is sold pursuant to McQuay's Standard Terms and Conditions of Sale and Limited Product Warranty.

All McQuay equipment is sold pursuant to McQuay's Standard Terms and Conditions of Sale and Limited Product Warranty. Consult your local McQuay Representative for warranty details. Refer to form 933-430285Y. To find your local representative, go to [www.mcquay.com](http://www.mcquay.com)

